



INTERNATIONAL INSTITUTE OF WELDING

A world of joining experience

XV-1439-13 ISO/FDIS 14346: Static design procedure for welded hollow-section joints - Recommendations

08.01.2013

COMMISSION XV

DESIGN, ANALYSIS AND FABRICATION OF WELDED STRUCTURES

XV-1439-13

ISO/FDIS 14346: Static design procedure for welded hollow-section joints - Recommendations

Author: ZHAO, Xiao-Ling (AUS)

Chair, Subcommittee XV-E
Department of Civil Engineering, Monash University
Clayton, VIC 3168
Australia
zhao.xiao.ling@monash.edu

Abstract:

This International Standard gives guidelines for the design and analysis of welded uniplanar and multiplanar joints in lattice structures composed of circular (CHS), square (SHS) or rectangular (RHS) hollow sections, and of uniplanar joints in lattice structures composed of combinations of hollow sections with open sections under static loading. This International Standard is applicable to CHS or RHS Y-, X and K-joints and their multiplanar equivalents, gusset plate to CHS or RHS joints, open-section and RHS to CHS joints, and hollow-section to open-section joints.

IIW Keywords:

hollow sections, static design, lattice structures, circular hollow sections, square hollow sections, rectangular hollow sections

Notes:

IIW Commission XV review purposes only
© ISO 2012

RECIPIENTS OF THIS DRAFT ARE INVITED TO SUBMIT, WITH THEIR COMMENTS, NOTIFICATION OF ANY RELEVANT PATENT RIGHTS OF WHICH THEY ARE AWARE AND TO PROVIDE SUPPORTING DOCUMENTATION.

IIW

Voting begins on:
2012-12-04

Voting terminates on:
2013-02-04

**Static design procedure for
welded hollow-section joints —
Recommendations**

*Procédure statique de conception des joints soudés à section creuse —
Recommandations*

RECIPIENTS OF THIS DRAFT ARE INVITED TO SUBMIT, WITH THEIR COMMENTS, NOTIFICATION OF ANY RELEVANT PATENT RIGHTS OF WHICH THEY ARE AWARE AND TO PROVIDE SUPPORTING DOCUMENTATION.

IN ADDITION TO THEIR EVALUATION AS BEING ACCEPTABLE FOR INDUSTRIAL, TECHNOLOGICAL, COMMERCIAL AND USER PURPOSES, DRAFT INTERNATIONAL STANDARDS MAY ON OCCASION HAVE TO BE CONSIDERED IN THE LIGHT OF THEIR POTENTIAL TO BECOME STANDARDS TO WHICH REFERENCE MAY BE MADE IN NATIONAL REGULATIONS.



Reference number
ISO/FDIS 14346:2012(E)

© ISO 2012

Copyright notice

This ISO document is a Draft International Standard and is copyright-protected by ISO. Except as permitted under the applicable laws of the user's country, neither this ISO draft nor any extract from it may be reproduced, stored in a retrieval system or transmitted in any form or by any means, electronic, photocopying, recording or otherwise, without prior written permission being secured.

Requests for permission to reproduce should be addressed to either ISO at the address below or ISO's member body in the country of the requester.

ISO copyright office
Case postale 56 • CH-1211 Geneva 20
Tel. + 41 22 749 01 11
Fax + 41 22 749 09 47
E-mail copyright@iso.org
Web www.iso.org

Reproduction may be subject to royalty payments or a licensing agreement.

Violators may be prosecuted.

Contents

	Page
Foreword	v
1 Scope	1
2 Normative references	1
3 Terms and definitions	1
4 Symbols and abbreviated terms	2
5 Requirements	5
6 Materials	12
7 Joint types	13
8 Joint classification	19
9 Limit states design	24
10 Partial load and safety factors for loads and resistances	25
11 Static design procedures	25
11.1 General	25
11.2 Design member forces	25
11.3 Design resistance	25
11.4 Design criteria	25
12 Design member forces	25
12.1 Analysis methods	25
12.2 Design member forces	26
13 Design criteria	26
13.1 Failure modes	26
13.2 Uniplanar joints	27
13.3 Uniplanar overlap joints with a CHS, RHS, I- or H-section chord	28
13.4 Special uniplanar joints	28
13.5 Multiplanar joints	30
14 Design resistance of uniplanar CHS braces to CHS chord joints	30
14.1 Design axial resistance	30
14.2 Design moment resistance	31
15 Design resistance of uniplanar gusset plates, I- or H-section braces or RHS braces to CHS chord joints	32
16 Design resistance of multiplanar joints with CHS chord	33
17 Design resistance of uniplanar RHS braces or CHS braces to RHS chord joints	34
17.1 Design axial resistance	34
17.2 Design moment resistance	36
18 Design resistance of uniplanar SHS or CHS braces to SHS chord joints	37
18.1 Design axial resistance	37
18.2 Design moment resistance	38
19 Design resistance of uniplanar gusset plate to RHS joints	38
20 Design resistance of multiplanar joints with RHS chord	39
21 Design resistance of uniplanar CHS or RHS braces to I- or H-section chord joints	40
21.1 Design axial resistance	40
21.2 Design moment resistance	41
22 Design resistance of uniplanar overlap joints with a CHS, RHS, I- or H-section chord	42
Annex A (informative) Quality requirements for hollow sections	46

Annex B (informative) Weld details	48
Annex C (informative) Partial safety factors on static strength	50
Bibliography	52

IIW Commission XV review purposes only

Foreword

ISO (the International Organization for Standardization) is a worldwide federation of national standards bodies (ISO member bodies). The work of preparing International Standards is normally carried out through ISO technical committees. Each member body interested in a subject for which a technical committee has been established has the right to be represented on that committee. International organizations, governmental and non-governmental, in liaison with ISO, also take part in the work. ISO collaborates closely with the International Electrotechnical Commission (IEC) on all matters of electrotechnical standardization.

International Standards are drafted in accordance with the rules given in the ISO/IEC Directives, Part 2.

The main task of technical committees is to prepare International Standards. Draft International Standards adopted by the technical committees are circulated to the member bodies for voting. Publication as an International Standard requires approval by at least 75 % of the member bodies casting a vote.

Attention is drawn to the possibility that some of the elements of this document may be the subject of patent rights. ISO shall not be held responsible for identifying any or all such patent rights.

ISO 14346 was prepared by the International Institute of Welding, which has been approved as an international standardizing body in the field of welding by the ISO Council.

Requests for official interpretations of any aspect of this International Standard should be directed to the ISO Central Secretariat, who will forward them to the IIW Secretariat for an official response.

IIW Commission XV review purposes only

Static design procedure for welded hollow-section joints — Recommendations

1 Scope

This International Standard gives guidelines for the design and analysis of welded uniplanar and multiplanar joints in lattice structures composed of circular (CHS), square (SHS) or rectangular (RHS) hollow sections, and of uniplanar joints in lattice structures composed of combinations of hollow sections with open sections under static loading. This International Standard is applicable to CHS or RHS Y-, X- and K-joints and their multiplanar equivalents, gusset plate to CHS or RHS joints, open-section and RHS to CHS joints, and hollow-section to open-section joints.

2 Normative references

The following referenced documents are indispensable for the application of this document. For dated references, only the edition cited applies. For undated references, the latest edition of the referenced document (including any amendments) applies.

ISO 630 (all parts), *Structural steels*

ISO 14347, *Fatigue — Design procedure for welded hollow-section joints — Recommendations*

ISO/TR 25901, *Welding and related processes — Vocabulary*

3 Terms and definitions

For the purposes of this document, the terms and definitions given in ISO 14347, ISO/TR 25901, and the following apply.

3.1

chord face failure

chord plastification

plastic failure of the chord face or plastic failure of the chord cross-section

3.2

chord punching shear

crack initiation in a hollow-section chord wall leading to rupture of a brace member from the chord member

3.3

chord side wall failure

chord web failure

yielding, crushing or instability (crippling or buckling of the chord side wall or chord web) under the relevant brace member

3.4

cross-section classification

identification of the extent to which the resistance (to axial compression or bending moment) and rotation capacity of a cross-section are limited by its local buckling resistance

NOTE For example, four classes are given in Eurocode 3 (see EN 1993-1-1) together with three limits on diameter-to-thickness ratio for CHS or width-to-thickness ratio for RHS.

**3.5
joint configuration**

type or layout of the joint or joints in a zone within which the axes of two or more interconnected members or elements intersect

**3.6
local chord member yielding**

local buckling of the chord connecting face in an overlapped joint

**3.7
local yielding of overlapping brace
local yielding of overlapping plate
local yielding of brace
local yielding of plate**

cracking in the weld or in a brace member, or local buckling of a brace member with reduced effective width

**3.8
multiplanar joint**

in a lattice structure, a joint connecting members situated in more than one plane

**3.9
structural properties of a joint**

resistance to forces and moments in the connected members, deformation and/or rotation capacity

**3.10
uniplanar joint**

in a lattice structure, a joint connecting members situated in a single plane

4 Symbols and abbreviated terms

- A_i cross-sectional area of member i ($i = 0, 1, 2$)
- A_s shear area of a chord member
- b_e effective width of a plate or RHS brace member
- b_{ei} effective width of an overlapping RHS brace member at the chord connection
- b_{ej} effective width of an overlapped RHS brace member at the chord connection
- $b_{e,ov}$ effective width of an overlapping RHS brace member at the overlapped brace connection
- $b_{e,p}$ effective width for punching shear
- b_i overall out-of-plane width of a plate or RHS or I- or H-member i ($i = 0, 1, 2$)
- b_w effective width for the web of an I- or H-section, or RHS side wall
- C_1 coefficient used in the chord stress function Q_f as shown in Tables 2, 4, 6, and 9
- c coefficient defined in Table 13
- c_s coefficient for effective shear area
- d_e effective width of a CHS brace member
- d_{ei} effective width of an overlapping CHS brace member at the chord connection
- d_{ej} effective width of an overlapped CHS brace member at the chord connection

$d_{e,ov}$	effective width of an overlapping CHS brace member at the overlapped brace connection
d_i	overall diameter of CHS member i ($i = 0, 1, 2$)
d_w	depth of the web of an I- or H-section chord member ($d_w h_0 - 2t_0 - 2r$)
e	nodding eccentricity of a joint, shown in Figure 1 h), with a positive value of e representing an offset from the chord centreline towards the outside of the truss
F_{ax}	axial force in a brace member
$F_{gap,0}^*$	design resistance for the axial force in a chord member at the gap location
$F_{gap,0}$	design value of the axial force in a chord member at the gap location
F_i^*	design resistance of the joint, expressed in terms of the axial force in member i ($i = 1, 2$)
F_i	design value of the axial force in member i ($i = 0, 1, 2$)
$F_{pl,0}$	axial yield capacity of a chord member
F_s^*	design resistance for the shear force of the brace to chord connection in an overlapped joint
$F_{s,gap,0}$	design value of the shear force in a chord member at the gap location
$F_{s,pl,0}$	shear yield capacity of a chord member
$F_{s,0}$	design value of the shear force in a chord member
g	gap between the brace members in a K- or N-joint, defined in Figure 1 h)
g_t	transverse gap in KK-joints, defined in Figure 1 n)
h_i	overall in-plane depth of a plate or RHS or I- or H-section member i ($i = 0, 1, 2$)
h_z	distance between the centres of gravity of the effective parts of the brace (beam) as shown in Table 12
i	integer subscript used to designate a member of a joint: 0 denotes a chord member; 1, 2 denote the brace members. In joints with two brace members, 1 normally denotes the compression brace and 2 the tension brace. For a single brace, $i = 1$ whether it is subject to compression or tension. For an overlap type joint, i is the integer subscript to designate the overlapping brace
j	integer subscript used to designate the overlapped brace member in overlap type joints
k_b	factor defined in Table 3
$\ell_{b,eff}$	effective perimeter for local yielding of the (overlapping) brace
$\ell_{p,eff}$	effective perimeter for chord punching shear
M_i	design value of the moment in member i ($i = 0, 1, 2$)
$M_{ip,i}^*$	design resistance of the joint, expressed in terms of the in-plane moment in member i ($i = 1, 2$)

- $M_{ip,i}$ design value of the in-plane moment in member i ($i = 1, 2$)
- $M_{op,i}^*$ design resistance of the joint, expressed in terms of the out-of-plane moment in member i ($i = 1, 2$)
- $M_{op,i}$ design value of the out-of-plane moment in member i ($i = 1, 2$)
- $M_{pl,0}$ plastic moment capacity of a chord member
- N factor to account for chord stress in Q_f function (see applicable table)
- O_v overlap ratio, expressed as a percentage $O_v = \frac{q}{p} \times 100\%$
- $O_{v,limit}$ overlap limit for brace shear check
- P length of the projected contact area of the overlapping brace member onto the face of the chord, in the absence of the overlapped brace member, in a K- or N-joint, defined in Figure 1 i)
- Q_f chord stress function as defined in Tables 2, 4, 6, and 9
- Q_u function in the design resistance equation as defined in Tables 2, 3, 4, 6, 7, and 8
- Q_{ub} function in the design resistance equation for brace bending as defined in Table 4
- Q length of overlap, measured at the face of the chord, between one brace member toe and the position of the other projected brace member toe, in a K- or N-joint, defined in Figure 1 i)
- R fillet radius of an I- or H-section
- r_o external corner radius of an RHS
- T wall thickness
- t_i wall thickness (for CHS or RHS) or flange thickness (for I- or H-section) of member i ($i = 0, 1, 2$)
- t_w web thickness of an I- or H-section
- $W_{el,i}$ elastic section modulus of member i ($i = 0, 1, 2$)
- $W_{pl,i}$ plastic section modulus of member i ($i = 0, 1, 2$)
- α factor used in the expression of A_s in Tables 6 and 11
- β ratio of the mean diameter or width of the brace members, to that of the chord

for T, Y- and X-joints
$$\beta = \frac{d_1}{d_0} \quad \text{or} \quad \frac{d_1}{b_0} \quad \text{or} \quad \frac{b_1}{b_0}$$

for K- and N-joints
$$\beta = \frac{d_1 + d_2}{2d_0} \quad \text{or} \quad \frac{b_1 + b_2}{2b_0} \quad \text{or} \quad \frac{b_1 + b_2 + h_1 + h_2}{4b_0}$$

for plate to CHS
$$\beta = \frac{b_1}{d_0}$$

	for plate to RHS	$\beta = \frac{b_1}{b_0}$	
γ	ratio of the chord width or diameter to twice the chord thickness	$\gamma = \frac{d_0}{2t_0}$ or $\frac{b_0}{2t_0}$	
γ_F	partial load factor on applied loading		
γ_M	partial safety factor on joint resistance		
η	ratio of the brace member depth to the chord diameter or width	$\eta = \frac{h_1}{d_0}$ or $\frac{h_1}{b_0}$	
θ_i	included angle between brace member i and the chord ($i = 1, 2$)		
λ	slenderness		
μ	multiplanar factor defined in Tables 5 and 10		
σ_k	design stress for chord side wall failure		
σ_u	ultimate tensile stress		
σ_y	yield stress		
σ_{yi}	yield stress of member i ($i = 0, 1, 2$)		
ϕ	angle between the planes in a multiplanar joint defined in Figures 1 j) to o), or resistance factor		
χ	reduction factor for (column) buckling		
CHS	circular hollow section		
RHS	rectangular hollow section		
SHS	square hollow section		

5 Requirements

The following conditions are requirements for hollow-section joints.

- Steel grades shall be according to Clause 6.
- Hollow-section joint types shall be according to Clause 7.
- The nominal wall thickness of hollow sections shall be limited to a minimum of 2,5 mm.
- For hollow-section chords with a wall thickness greater than 25 mm, the steel shall meet adequate through thickness properties as specified in ISO 630.
- The ends of members that meet at a joint shall be prepared in such a way that their cross-sectional shape is not modified. Flattened end joints and cropped end joints are not covered in this International Standard.
- Where brace members are welded to a chord member, the included angle between brace and chord (θ_i) should be at least 30°. This is to ensure that proper welds can be made. For angles less than 30°, confirmation that sound welds can be made should be obtained from the fabricator.

- In gap-type joints, to ensure that there is adequate clearance to form satisfactory welds, the gap between adjacent brace members shall not be less than the sum of the brace member thicknesses ($t_1 + t_2$).
- In overlap-type joints, the overlap shall be large enough to ensure that the interconnection of the brace members is sufficient for adequate shear transfer from one brace to the other. In any case, the overlap ratio (defined in Clause 4) shall be at least 25 %.
- Where overlapping brace members are of different widths, the narrower member shall overlap the wider.
- Where overlapping brace members with the same width have different thicknesses and/or different strength grades, the member with the lowest $t_i\sigma_{yi}$ -value shall overlap the other member.
- In gap and overlap K-joints, the noding eccentricity, e , shown in Figure 1 h) and i), produces a primary bending moment which requires consideration when designing truss members.
- In gap and overlap K-joints, restrictions are placed on the noding eccentricity, e , shown in Figure 1 h) and i). Within the specified limits ($e \leq 0,25d_0$ or $e \leq 0,25h_0$), the bending moment due to this eccentricity is taken into account, for its effect on joint resistance, in the Q_f term (a function to account for chord stress at the connection face). If the noding eccentricity, e , exceeds the limits in the previous sentence, the effect of the resulting bending moment on the joint resistance shall be taken into account by distributing part of the total eccentricity moment to the brace members. (In such cases, the joint resistance shall then be determined by checking the interaction of brace axial load and brace bending moment.)
- For joints with one (or both) chord end(s) not connected to other members, the chord shall be extended from the centre of the joint over a length of $3,5d_0$ or $3,5b_0$ or the end(s) shall be welded to a cap plate with a thickness of at least $1,5t_0$ or 10 mm.

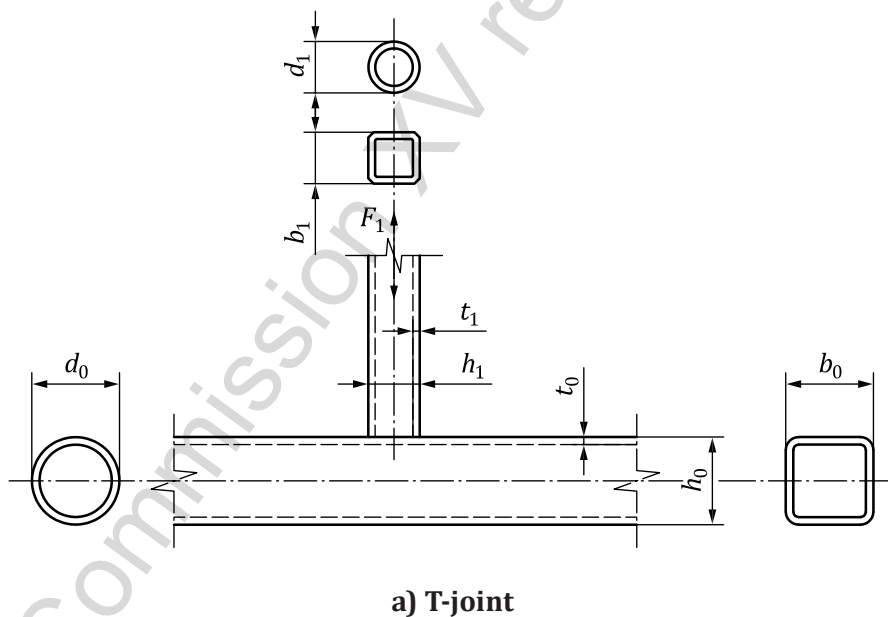

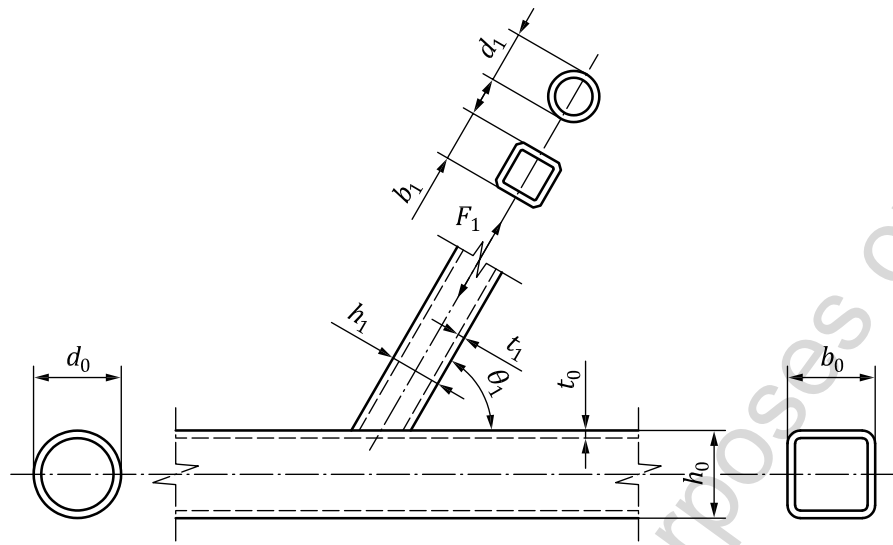

b) Y-joint

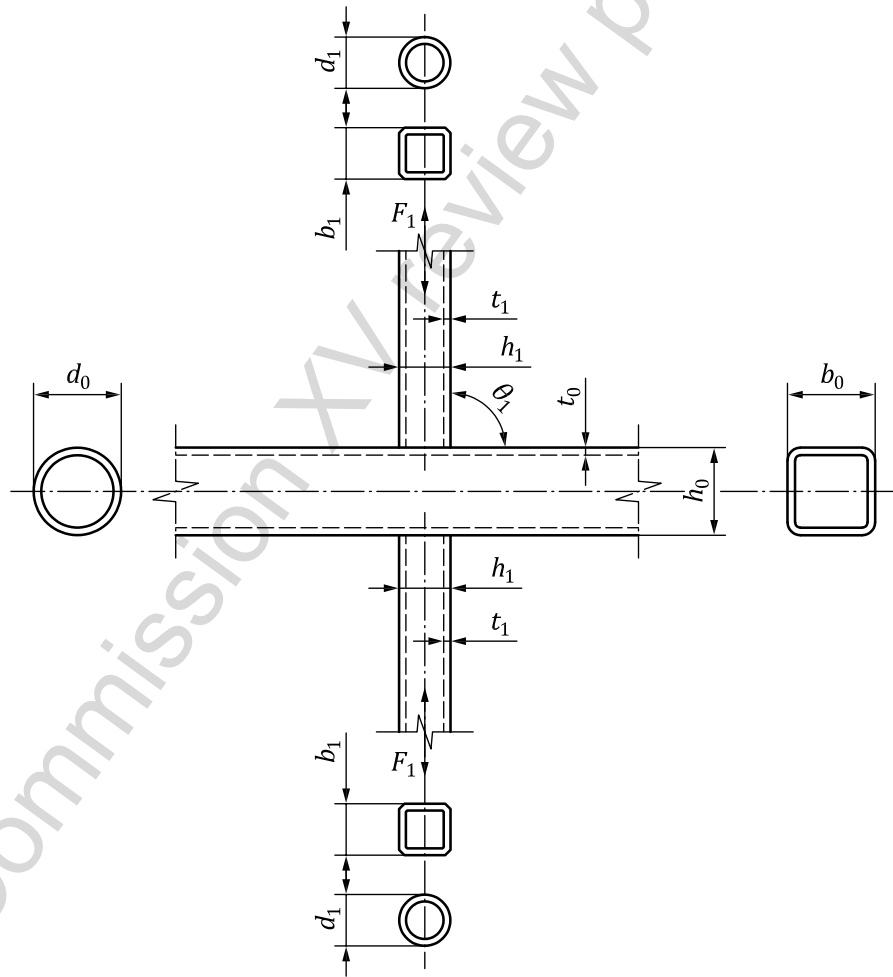

c) X-joint

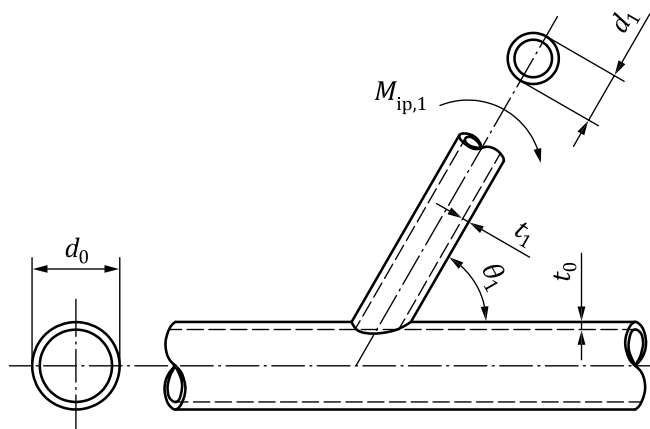

d) Y-joint (CHS chord) with brace in-plane bending

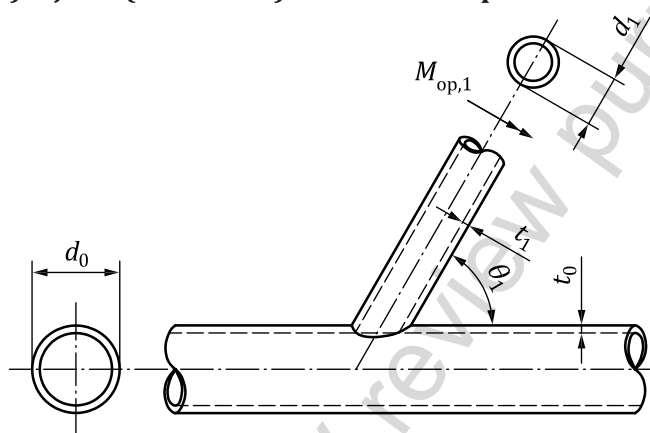

e) Y-joint (CHS chord) with brace out-of-plane bending

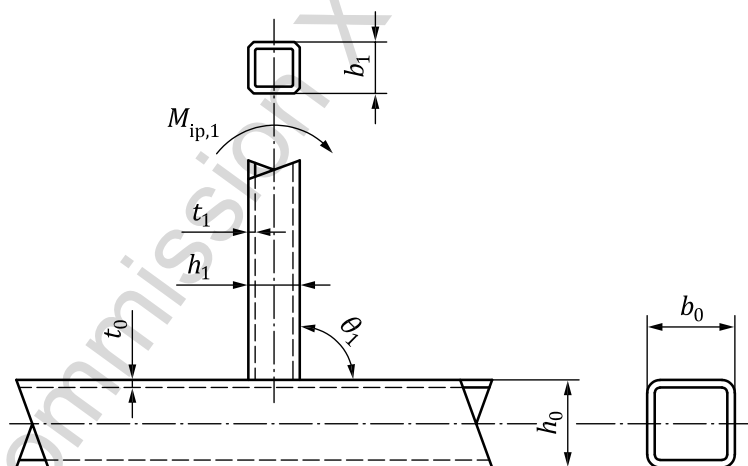

f) Y-joint (RHS chord) with brace in-plane bending

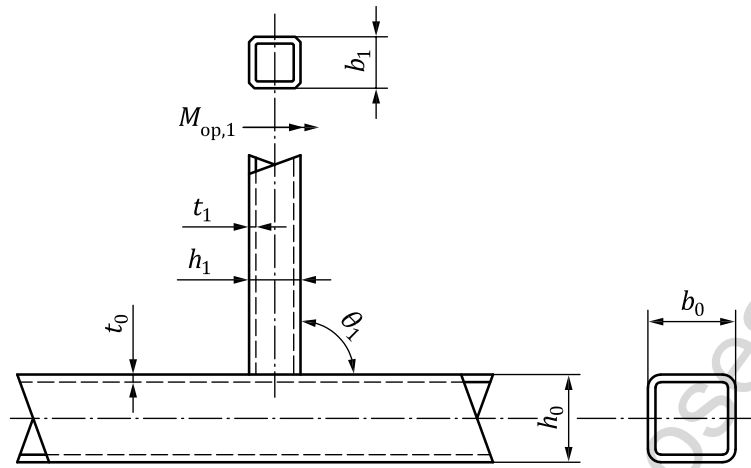

g) Y-joint (RHS chord) with brace out-of-plane bending

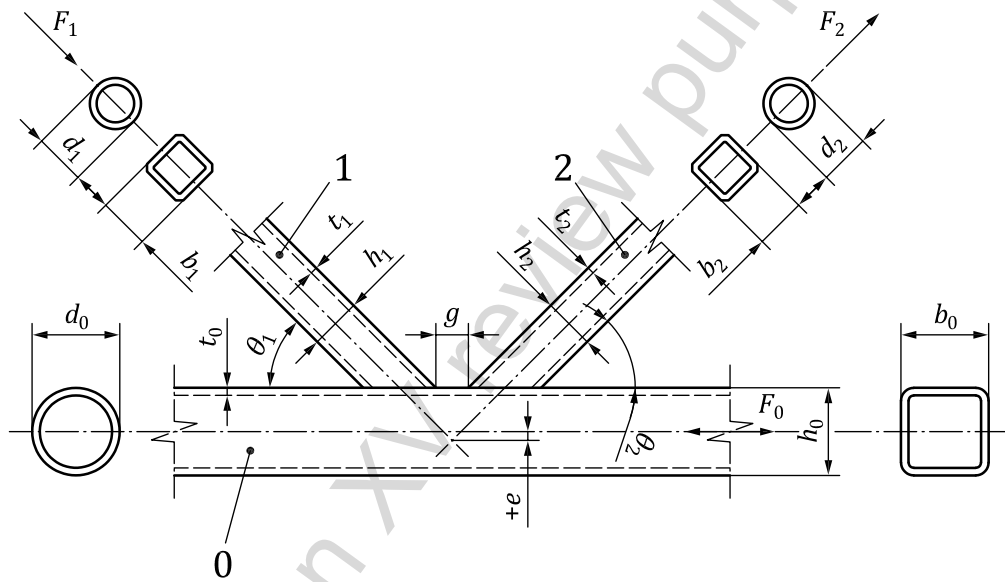

h) gap K-joint

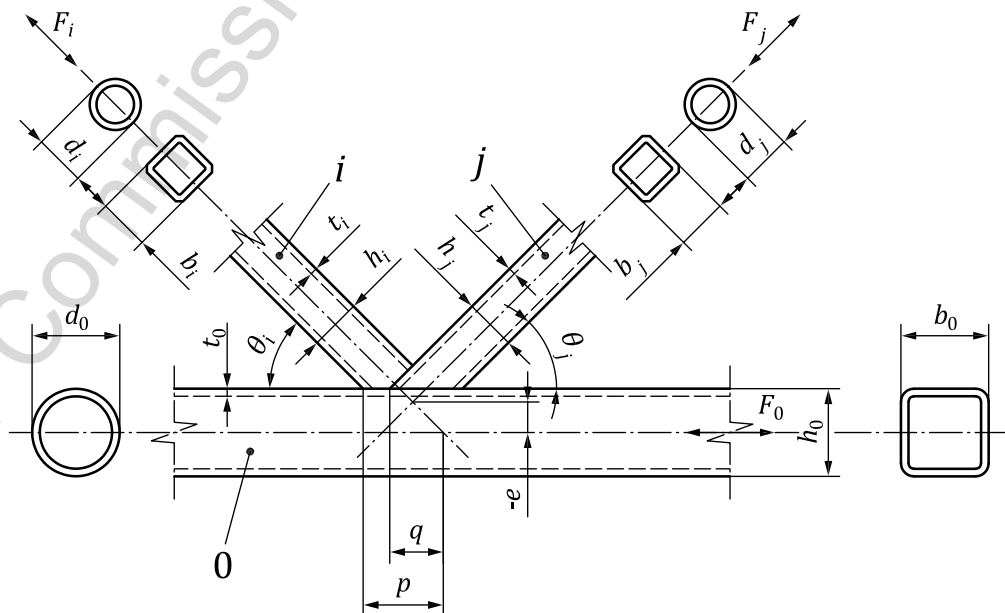

i) overlap K-joint

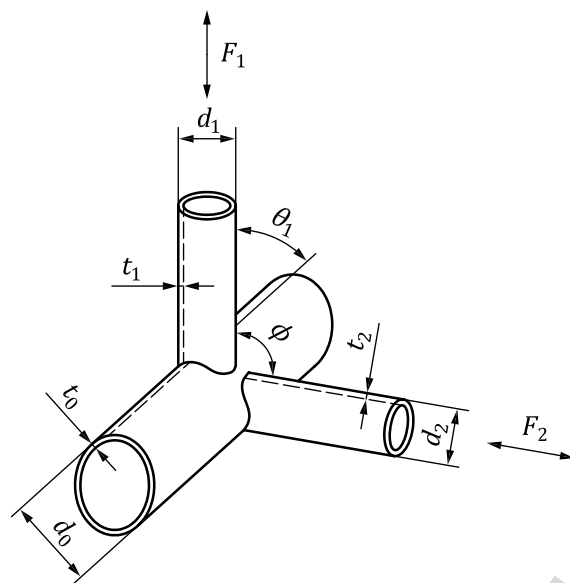

j) CHS TT-joint

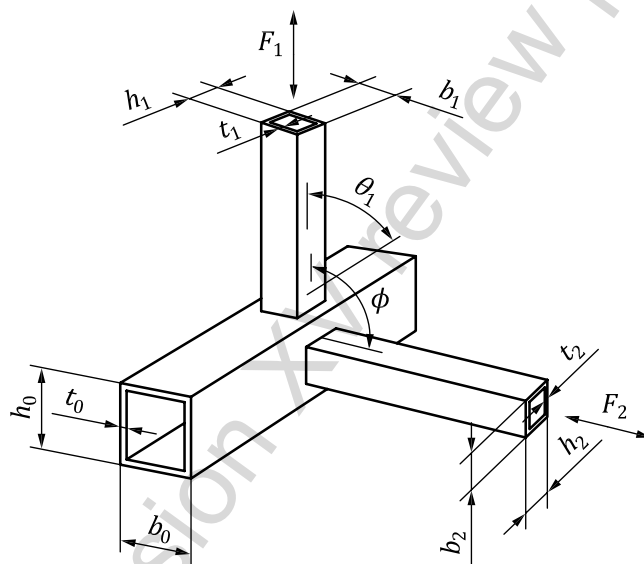

k) RHS TT-joint

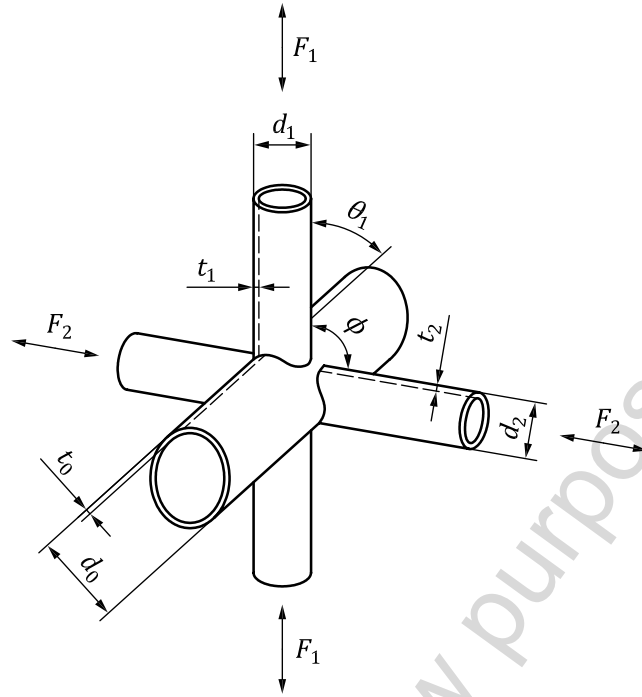

l) CHS XX-joint

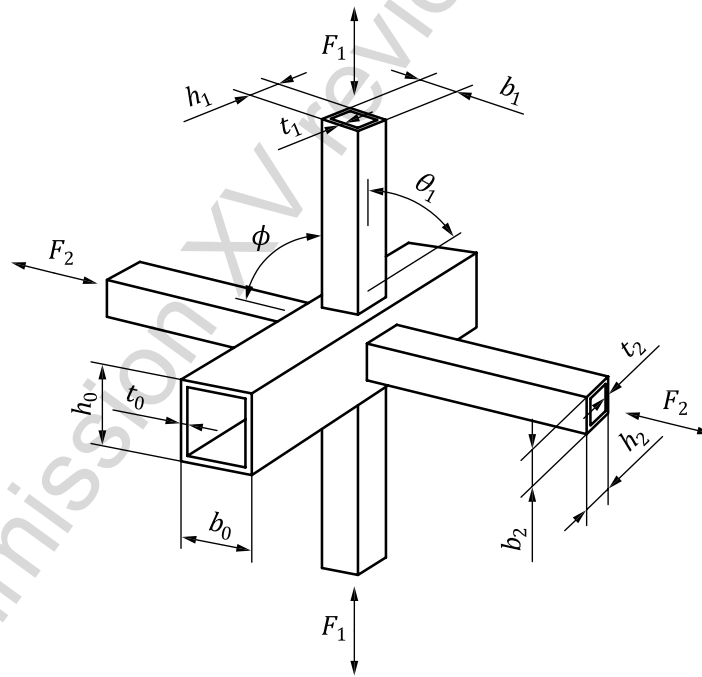

m) RHS XX-joint

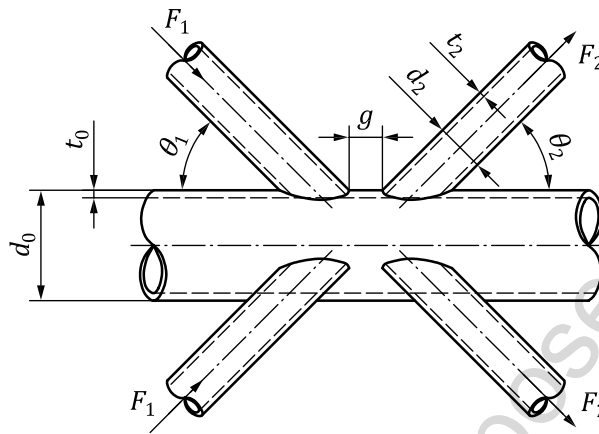
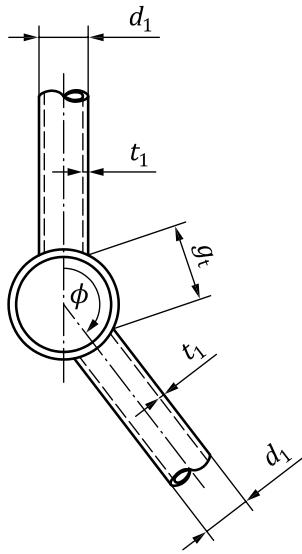

n) CHS gap KK-joint

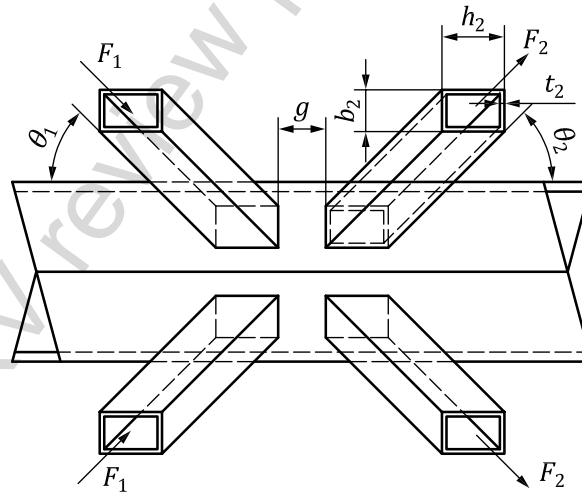
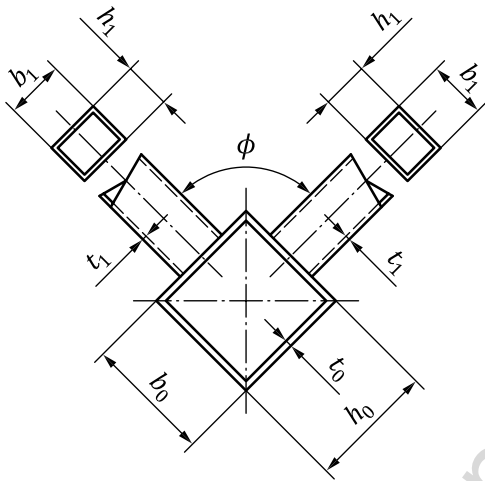

o) RHS gap KK-joint

Key

- 0 chord
- 1 compression brace
- 2 tension brace
- i* overlapping brace
- j* overlapped brace

Figure 1 — Joints between hollow sections

6 Materials

This International Standard is valid for both hot-finished (hot-formed) and cold-formed steel hollow sections. The manufactured hollow sections shall comply with the applicable national manufacturing specification for structural hollow sections. The nominal yield stress of hot-finished hollow sections and the nominal yield stress of the cold-formed hollow sections shall not exceed 460 N/mm² (MPa). Further criteria are given in 11.3. These nominal yield stresses pertain to the finished product, at the stipulated test locations.

7 Joint types

The joints covered in this International Standard consist of:

- CHS or RHS as used in uniplanar trusses or girders, such as Y- (with T- a special case thereof), X- and K- (with N- a special case thereof) joints (examples of which are given in Figure 1) and their multiplanar equivalents;
- gusset plate to CHS or RHS joints (examples of which are given in Figure 2);
- open-section and RHS to CHS joints (examples of which are given in Figure 3);
- hollow-section to open-section joints (examples of which are given in Figure 4).

Geometric parameters for various joints are defined in Figures 1 to 4. Recommended weld details for hollow-section joints are given in Annex B.

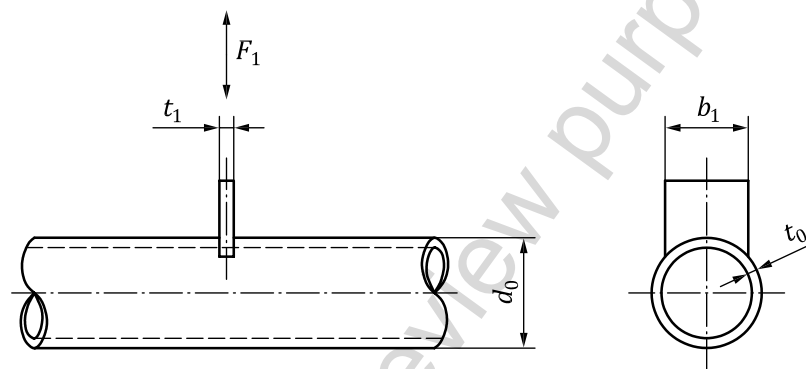

a) T-joint — transverse plate to CHS

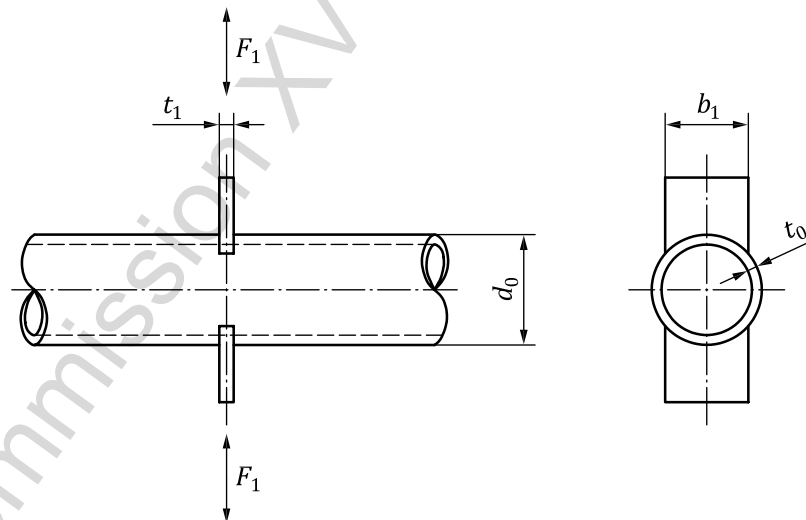

b) X-joint — transverse plate to CHS

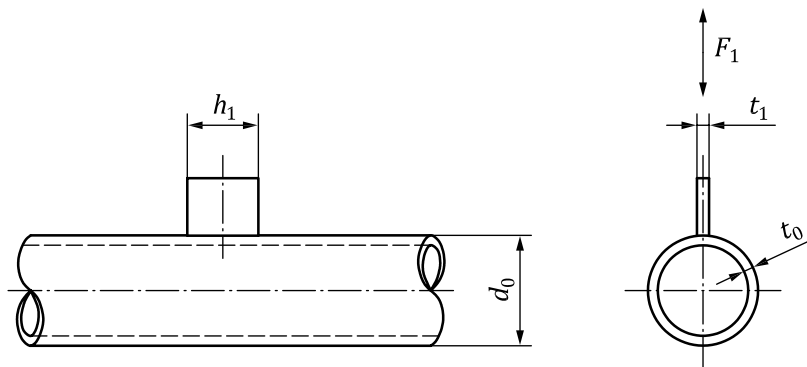

c) T-joint — longitudinal plate to CHS

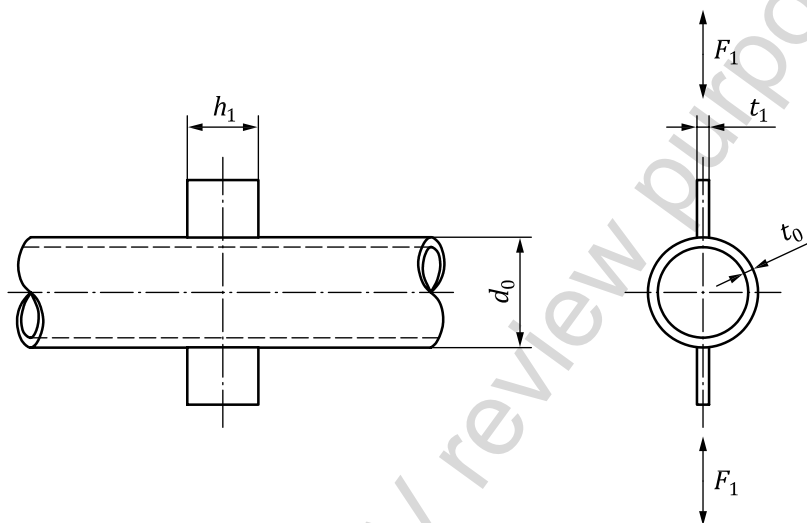

d) X-joint — longitudinal plate to CHS

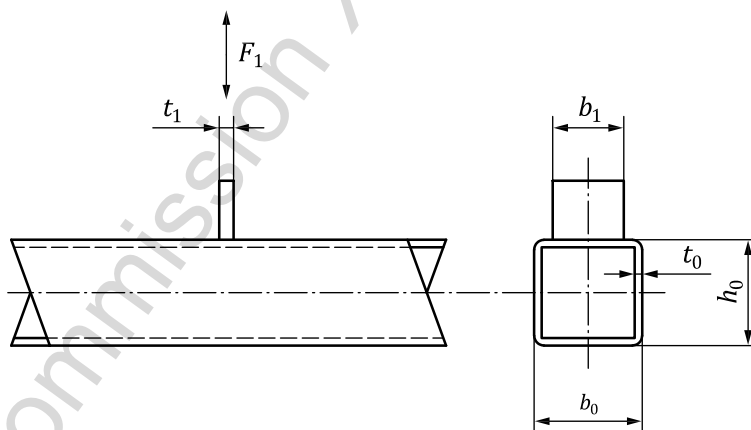

e) T-joint — transverse plate to RHS

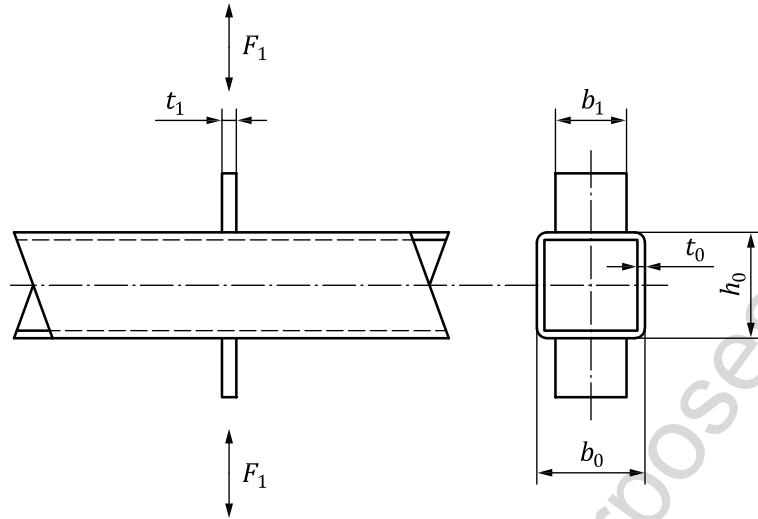

f) X-joint — transverse plate to RHS

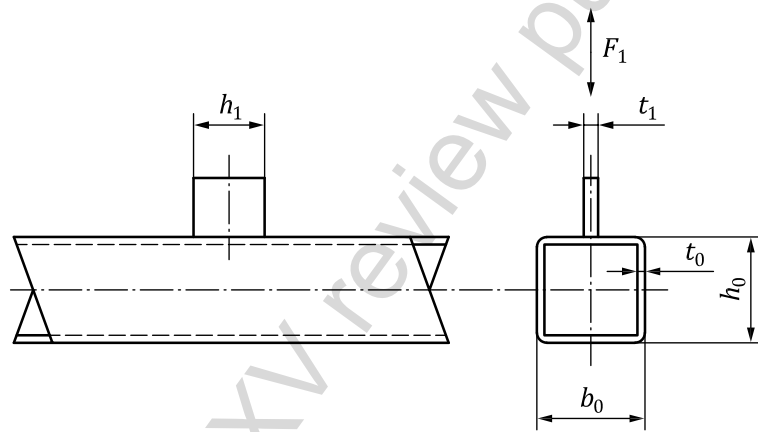

g) T-joint — longitudinal plate to RHS

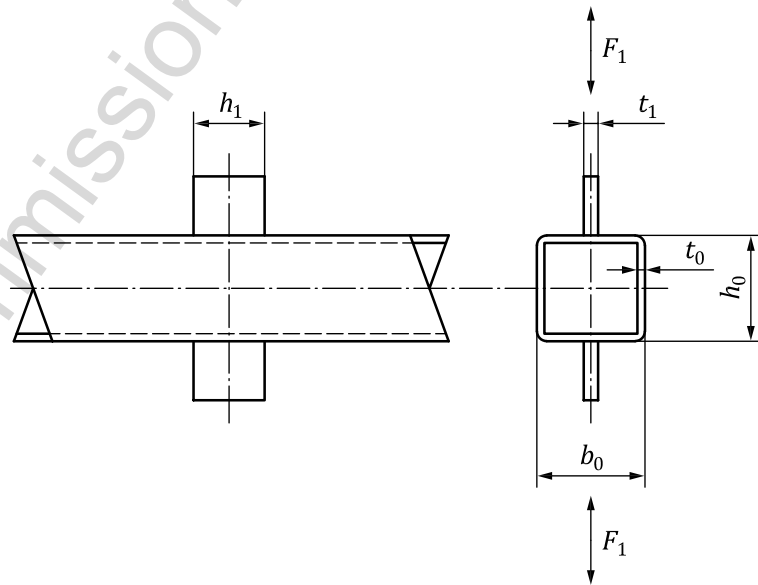

h) X-joint — longitudinal plate to RHS

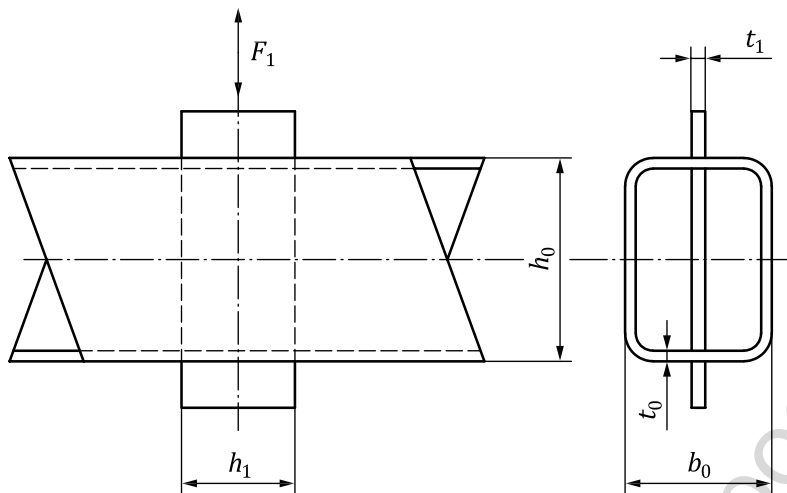

i) T-joint — longitudinal through plate to RHS

Figure 2 — Joints between gusset plates and CHS or RHS chords

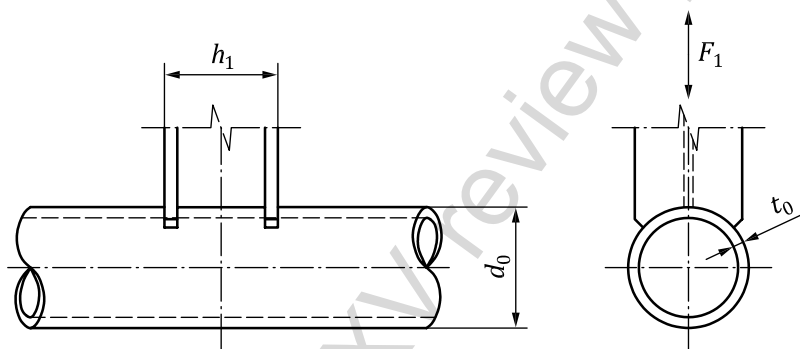

a) T-joint

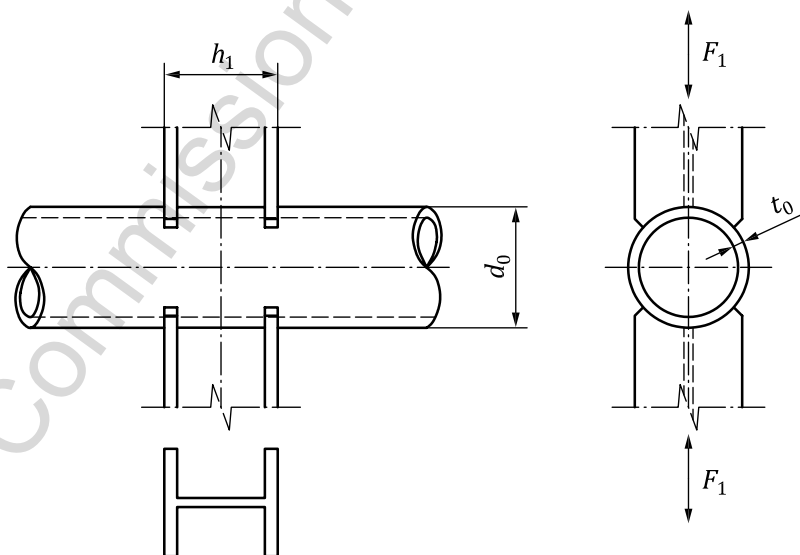

b) X-joint

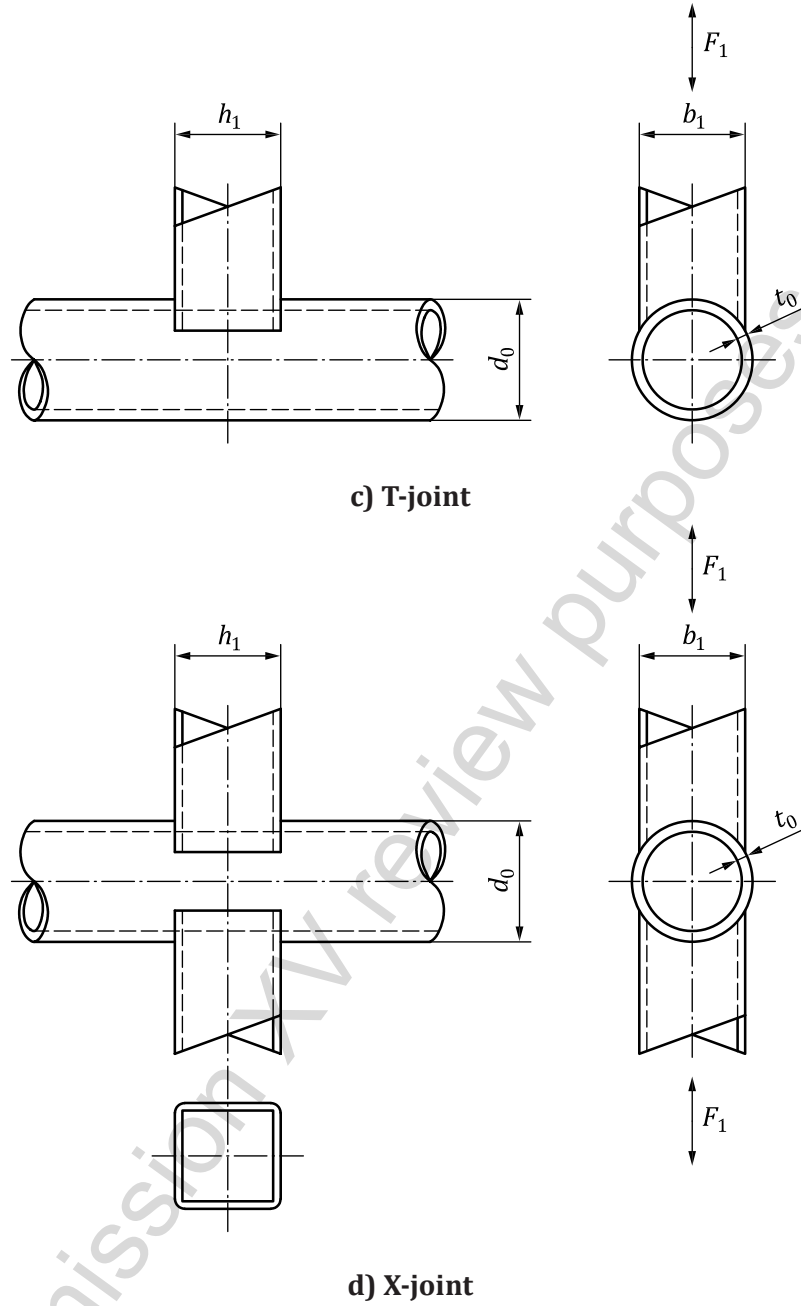
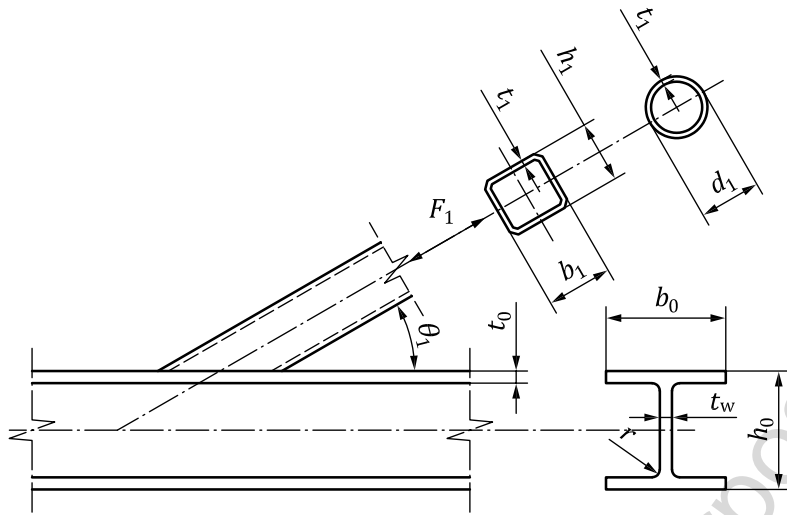
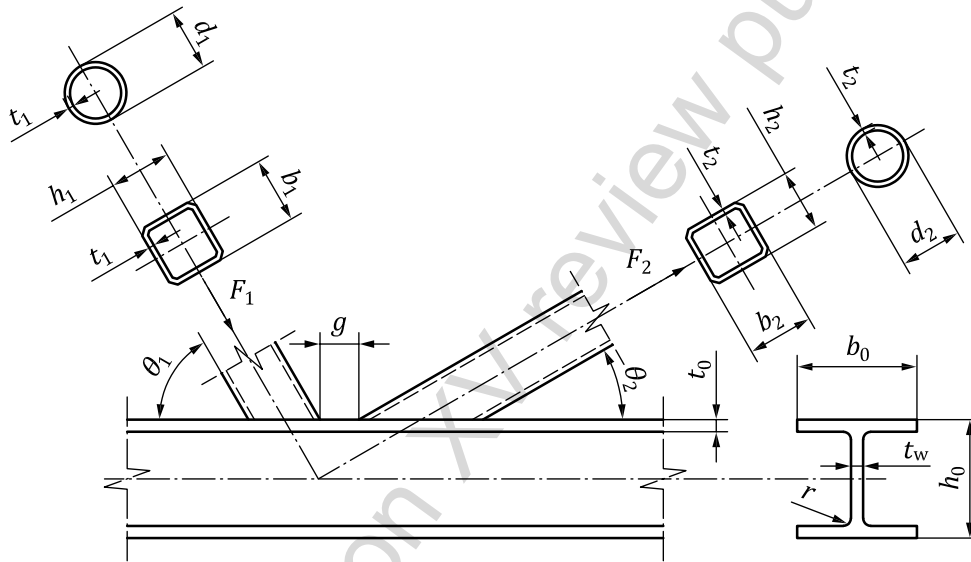

Figure 3 — Joints between open section or RHS braces and CHS chords



a) Y-joint



b) gap K-joint

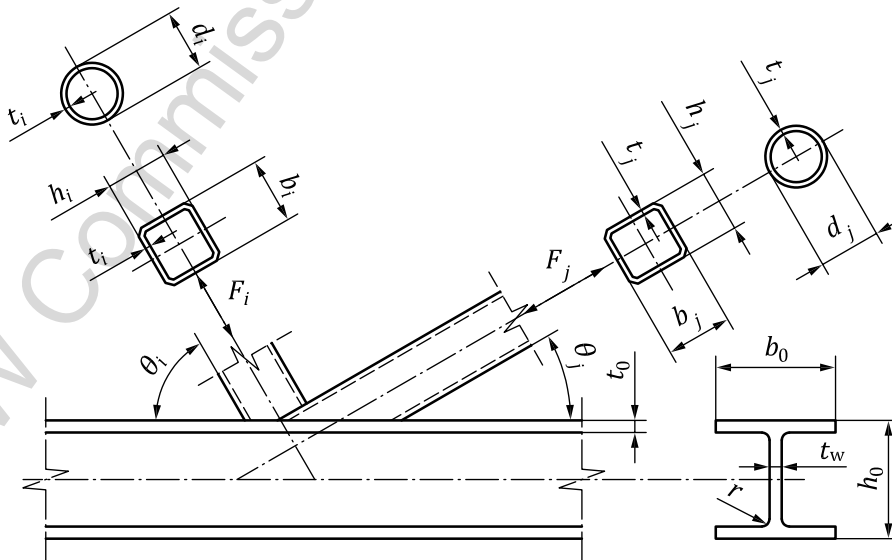

c) overlap K-joint

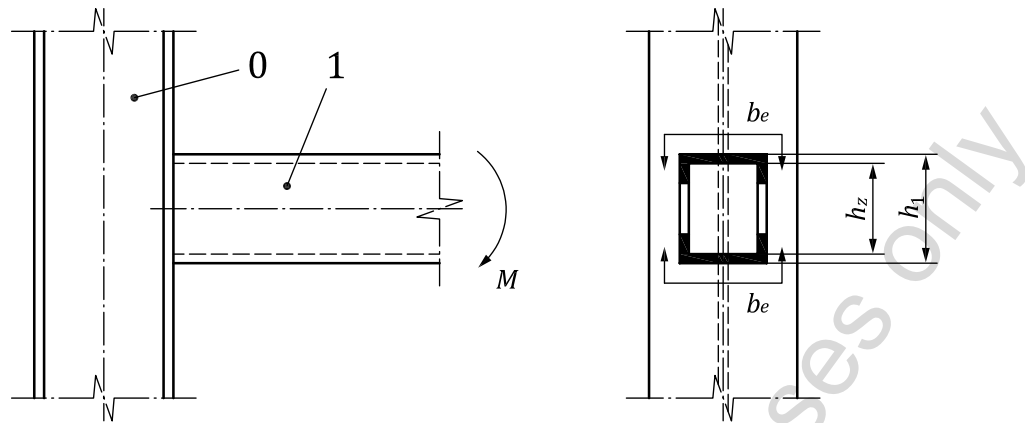

d) T-joint subject to in-plane bending

Key

- 0 I- or H-section chord
- 1 RHS brace (beam)

Figure 4 — Joints between CHS or RHS braces and open-section chords**8 Joint classification**

Hollow-section planar truss joints consist of one or more brace members that are directly welded to a continuous chord that passes through the joint. The classification of hollow-section truss-type joints as K- (which includes N-), Y- (which includes T-) or X-joints is based on the method of force transfer in the joint, not on the physical appearance of the joint. The joint types can be defined as follows.

- a) When the force component normal to the chord in a brace member ($F_{ax}\sin\theta$) is equilibrated by beam shear in the chord member, the joint is classified as a T-joint when the brace is perpendicular to the chord, otherwise it is classified as a Y-joint.
- b) When the force component normal to the chord in a brace member ($F_{ax}\sin\theta$) is essentially equilibrated (within 20 %) by loads in other brace member(s) on the same side of the joint, the joint is classified as a K-joint. The relevant gap is, in principle, between the primary brace members whose loads equilibrate. An N-joint is to be considered as a type of K-joint with one brace at 90° .
- c) When the force component normal to the chord ($F_{ax}\sin\theta$) is transmitted through the chord member and is equilibrated by brace member(s) on the opposite side, the joint is classified as an X-joint.

Examples of such classification are shown in Figure 5.

When brace members transmit part of their load as K-joints and part of their load as T-, Y-, or X-joints, the adequacy of each brace needs to be determined by linear interaction of the proportion of the brace load involved in each type of load transfer. One K-joint, in Figure 5 b), illustrates that the brace force components normal to the chord member may differ by as much as 20 % and still be deemed to exhibit K-joint behaviour. This is to accommodate slight variations in brace member forces along a typical truss, caused by a series of panel point loads. The N-joint in Figure 5 c), however, has a ratio of brace force components normal to the chord member of 2:1. That particular joint needs to be analysed as both a “pure” K-joint (with balanced brace forces) and an X-joint (because the remainder of the diagonal brace

load is being transferred through the joint), as shown in Figure 6. For the diagonal tension brace in that particular joint, one would need to check that:

$$\frac{0,5F_{ax}}{F_K^*} + \frac{0,5F_{ax}}{F_X^*} \leq 1,0$$

where

F_K^* is the resistance of a K-joint;

F_X^* is the resistance of an X-joint.

IIW Commission XV review purposes only

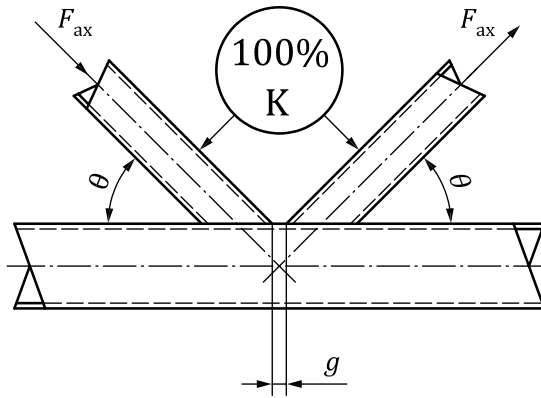

a)

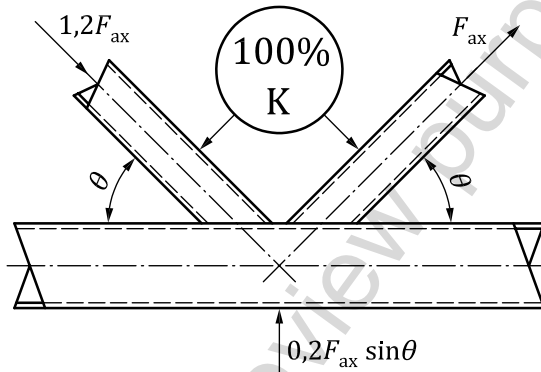

b)

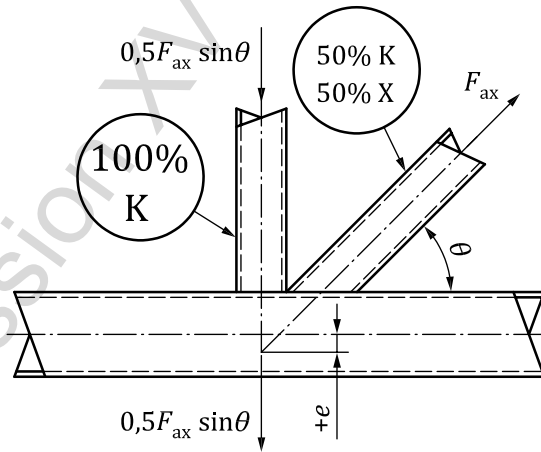

c)

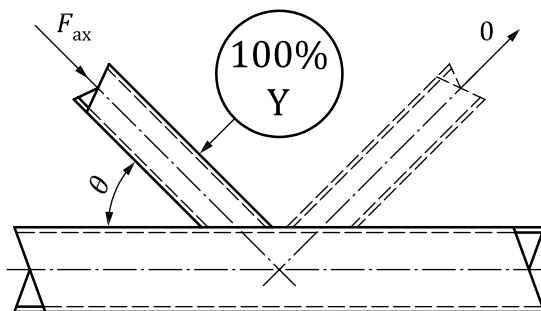

d)

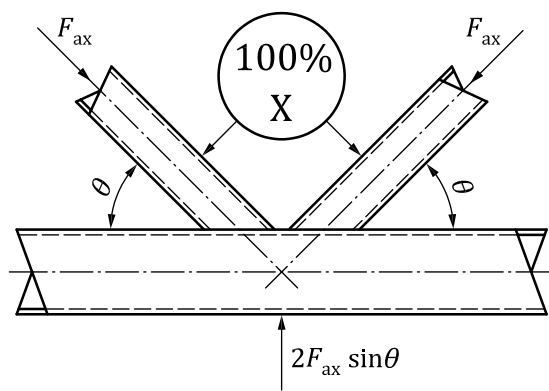

e)

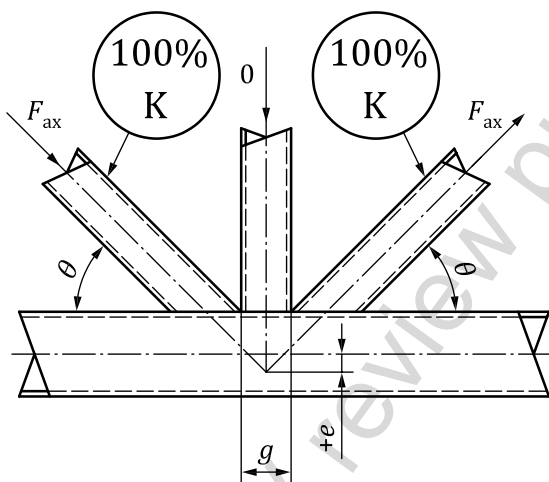

f)

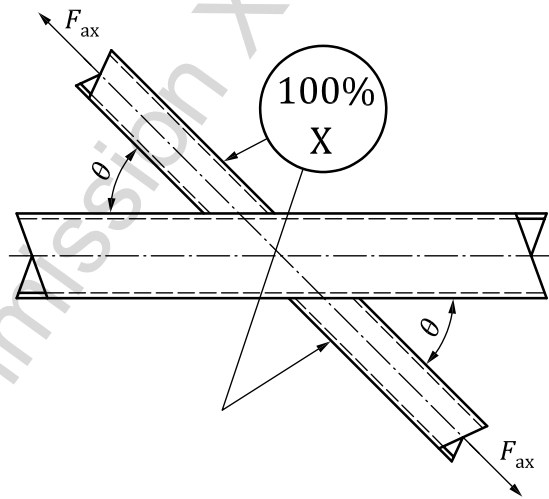

g)

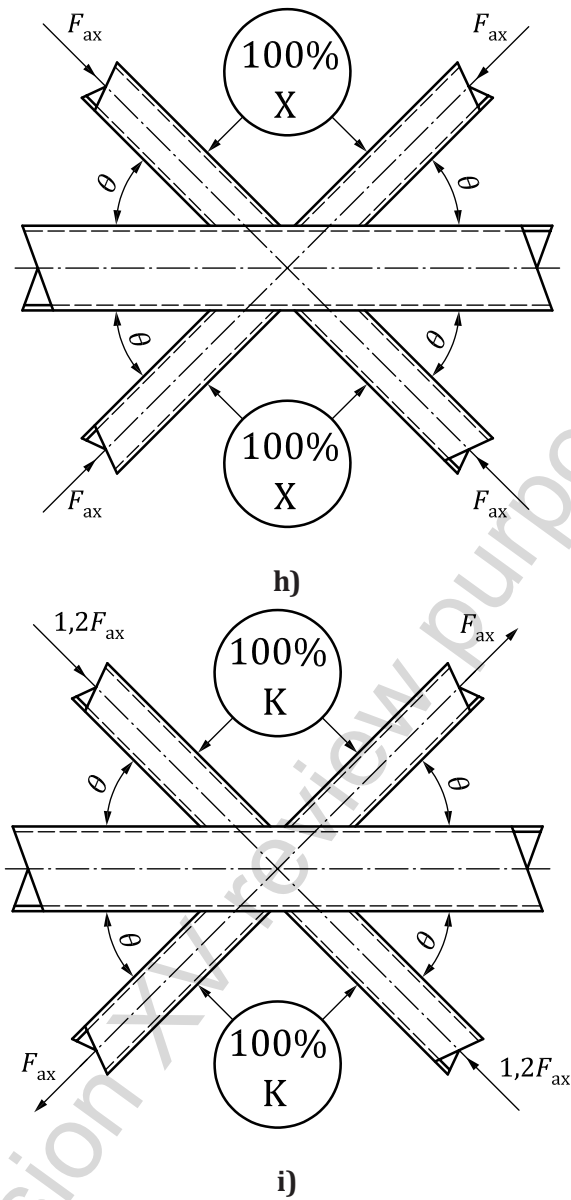

Figure 5 — Examples of hollow-section joint classification

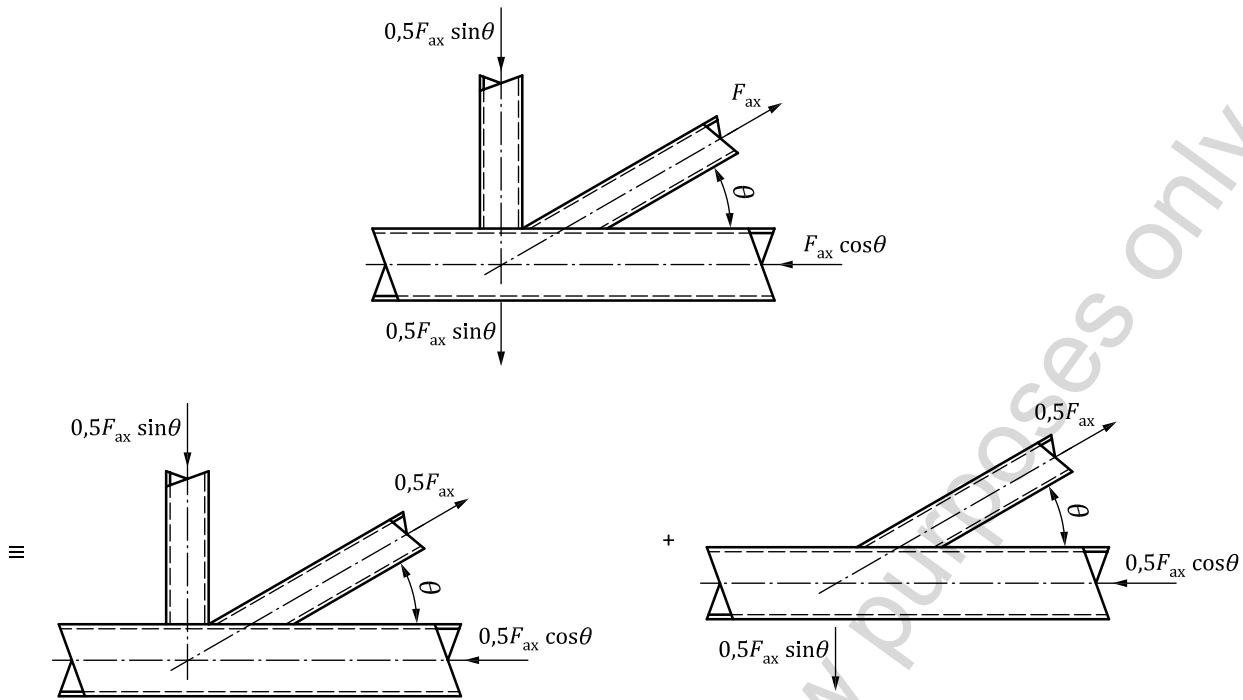

Figure 6 — Checking of an N-joint with unbalanced brace member loads

9 Limit states design

The design methodology used herein is a limit states design (LSD) procedure, also called a load and resistance factor design (LRFD) procedure. All loads are considered to be factored loads and the factored load effect must not exceed the design resistance, where the design resistance is based on an ultimate limit state (or states) corresponding to the maximum load carrying capacity or the load at a maximum deformation limit.

NOTE In the analyses for the determination of the design strengths, the assumed mean values and coefficients of variation for the dimensional, geometric and mechanical properties are listed in Table 1.

Table 1 — Mean values and coefficients of variation for the dimensional, geometric and mechanical properties

Parameter (actual measured/specified nominal ratio)	Mean value	Coefficient of variation	Effect
CHS or RHS thickness, t_i	1,0	0,05	Important
CHS diameter, d_i , or RHS width, b_i , or depth, h_i	1,0	0,005	Negligible
Angle, θ_i	1,0	1°	Negligible
Relative gap, $g' = g/t_0$	1,0	0,06	Important
Relative chord stress parameter, n	1,0	0,05	Important
Yield stress, σ_y	1,18	0,075	Important
Mean values or tolerances considerably deviating from these values can affect the resulting design value.			

10 Partial load and safety factors for loads and resistances

10.1 The partial load factors for applied loading, for the ultimate (γ_F) limit state, shall be taken from the relevant building code or specification being used.

10.2 Partial safety factors (γ_M) or resistance factors (ϕ) for hollow-section joints have already been incorporated into the design resistance formulae given in Clauses 14 to 22. For informational purposes, the partial safety factors used in the various joint resistance formulae are given in Table C.1.

11 Static design procedures

11.1 General

The static design procedures can be summarized as the following three steps:

- a) Step one: determine the design member forces in the brace(s) and chord;
- b) Step two: determine the design resistance of the joint;
- c) Step three: apply design criteria to assess if the joint resistance is sufficient.

11.2 Design member forces

The design member forces shall be determined using Clause 12.

11.3 Design resistance

The design resistance for various types of joints is given in Clauses 14 to 22, where the partial safety factors listed in Table C.1 have already been incorporated. For material with a nominal yield stress (σ_y) exceeding 355 N/mm², the joint resistances specified in this International Standard shall be multiplied by 0,9. In addition, if the nominal yield stress exceeds 0,8 of the nominal ultimate stress (σ_u) then the design yield stress shall be taken as $0,8\sigma_u$.

11.4 Design criteria

The design member forces determined in 11.2 shall not exceed the design resistance given in 11.3 as appropriate. The design criteria are given in Clause 13.

12 Design member forces

12.1 Analysis methods

12.1.1 For welded hollow-section structures, design member forces require determination by analysis of the complete structure, in which nodal eccentricity of the member centrelines at the joint is taken into account.

12.1.2 Simplified analysis methods are acceptable for triangulated trusses or lattice girders with eccentricities $e \leq 0,25d_0$ or $e \leq 0,25h_0$ for gap and overlap K-joints; these are as follows.

- a) Pin-jointed analysis. Moments due to eccentricity need to be taken into account for the design of chords.
- b) Continuous chords with pin-ended braces. Axial forces and bending moments in the members can be determined using a structural analysis assuming a continuous chord and pin-ended braces (see Figure 7). This produces axial forces in the braces, and both axial forces and bending moments in the chord. This modelling assumption is particularly appropriate for loads on the chord members which are away from the node points or panel points.

12.1.3 Rigid frame analysis shall be used for two- or three-dimensional Vierendeel girders.

12.1.4 Other rational analysis procedures consistent with the joint stiffnesses may be used.

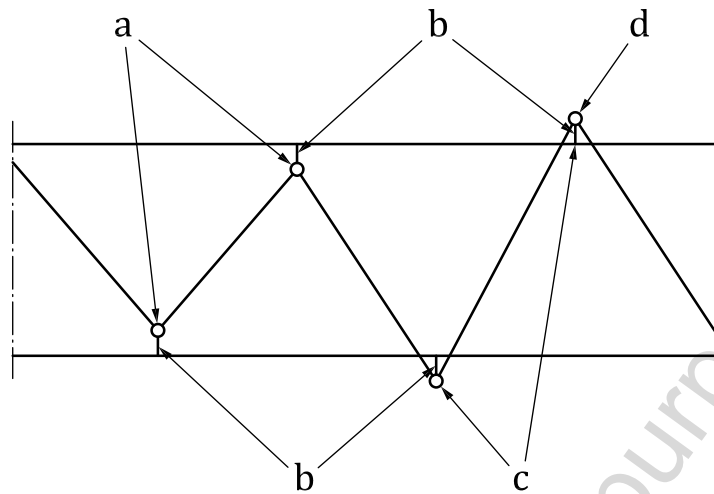

Key

- a noding condition for most overlap connections
- b extremely stiff members
- c noding condition for most gap connections
- d pin

Figure 7 — Possible frame modelling assumption

12.2 Design member forces

The following design member forces can be determined from 12.1:

- F_i design axial force in the chord ($i = 0$) or in the brace ($i = 1, 2$);
- $F_{s,0}$ design shear force in the chord;
- $M_{ip,i}$ design in-plane moment in the brace ($i = 1, 2$);
- $M_{op,i}$ design out-of-plane moment in the brace ($i = 1, 2$);
- M_0 design moment in the chord.

13 Design criteria

13.1 Failure modes

The design resistance of joints mentioned in 11.3 shall be based on the following failure modes as applicable:

- a) chord face failure or chord plastification;
- b) chord side wall failure (or chord web failure);
- c) chord shear;
- d) chord punching shear;

- e) local yielding of (overlapping) brace (or plate);
- f) local chord member yielding;
- g) brace shear.

NOTE These failure mode descriptions are used in Tables 2 to 15, which list design resistances.

Weld failure shall be avoided.

13.2 Uniplanar joints

13.2.1 General

For joint types described in Clauses 14, 15, 17, 18, 19, 21 and 22, the following design criteria apply.

- a) For joints within the range of validity given in Tables 2 to 15, only failure modes listed in the resistance tables need to be considered. The design resistance of a joint shall be taken as the minimum value for these criteria.
- b) For joints outside the range of validity mentioned in a), all criteria given in 13.1 shall be considered.

In joints with the brace member(s) subject only to axial forces, the design axial force F_i shall not exceed the design axial resistance of the welded joint F_i^* , expressed as an axial force in the brace member.

13.2.2 Uniplanar joints with CHS chord

The following design criteria apply:

- a) for overlap joints, see 13.3;
- b) for special uniplanar joints with braces on both sides of the chord, see 13.4;
- c) In joints with the brace member(s) subjected to combined bending and axial forces, apply the following:

$$\frac{F_i}{F_i^*} + \left(\frac{M_{ip,i}}{M_{ip,i}^*} \right)^2 + \frac{M_{op,i}}{M_{op,i}^*} \leq 1,0$$

where

F_i , $M_{ip,i}$, and $M_{op,i}$ are member forces determined in Clause 12;

F_i^* , $M_{ip,i}^*$ and $M_{op,i}^*$ are design resistances determined in Clauses 14 and 15.

13.2.3 Uniplanar joints with RHS chord

The following design criteria apply:

- a) for overlap joints, see 13.3;
- b) for special uniplanar joints with braces on both sides of the chord, see 13.4;
- c) for welded T-, Y-, X-, and gap K-joints between SHS or CHS brace members and SHS chord members only, where the geometry of the joints is within the range of validity given in Table 6 and also satisfies the additional conditions given in Table 8, the only consideration is chord plastification;
- d) in joints with the brace member(s) subjected to a combination of bending and axial forces, the following design criterion applies:

$$\frac{F_i}{F_i^*} + \frac{M_{ip,i}}{M_{ip,i}^*} + \frac{M_{op,i}}{M_{op,i}^*} \leq 1,0$$

where

F_i , $M_{ip,i}$ and $M_{op,i}$ are member forces determined in Clause 12;

F_i^* , $M_{ip,i}^*$ and $M_{op,i}^*$ are design resistances determined in Clauses 17 and 18.

13.2.4 Uniplanar joints with CHS or RHS brace to I- or H-section chord

The following design criteria apply:

- a) for overlap joints, see 13.3;
- b) in joints with the brace member(s) subjected to a combination of in-plane bending and axial forces, the following applies:

$$\frac{F_i}{F_i^*} + \frac{M_{ip,i}}{M_{ip,i}^*} \leq 1,0$$

where

F_i and $M_{ip,i}$ are member forces determined in Clause 12;

F_i^* and $M_{ip,i}^*$ are design resistances determined in Clause 21.

13.3 Uniplanar overlap joints with a CHS, RHS, I- or H-section chord

Requirements are:

- a) the design axial forces in overlap joints shall not exceed the design axial resistances given in Tables 13 and 14;
- b) the local yielding of the overlapping brace criterion and the local chord yielding criterion in Table 13 always apply;
- c) the brace shear criterion in Table 14 should only be checked if $O_v > O_{v,limit}$:

$O_{v,limit} = 60\%$ if the hidden seam of the overlapped brace is not welded,

$O_{v,limit} = 80\%$ if the hidden seam of the overlapped brace is welded.

For overlap joints with $h_i < b_i$ and/or $h_j < b_j$, the brace shear criterion shall always be checked.

13.4 Special uniplanar joints

The design resistance of several types of special uniplanar joints shown in Figure 8 a) to d), which are not dealt with in 13.2 and 13.3, can be directly related to that of the basic types (i.e. X and K).

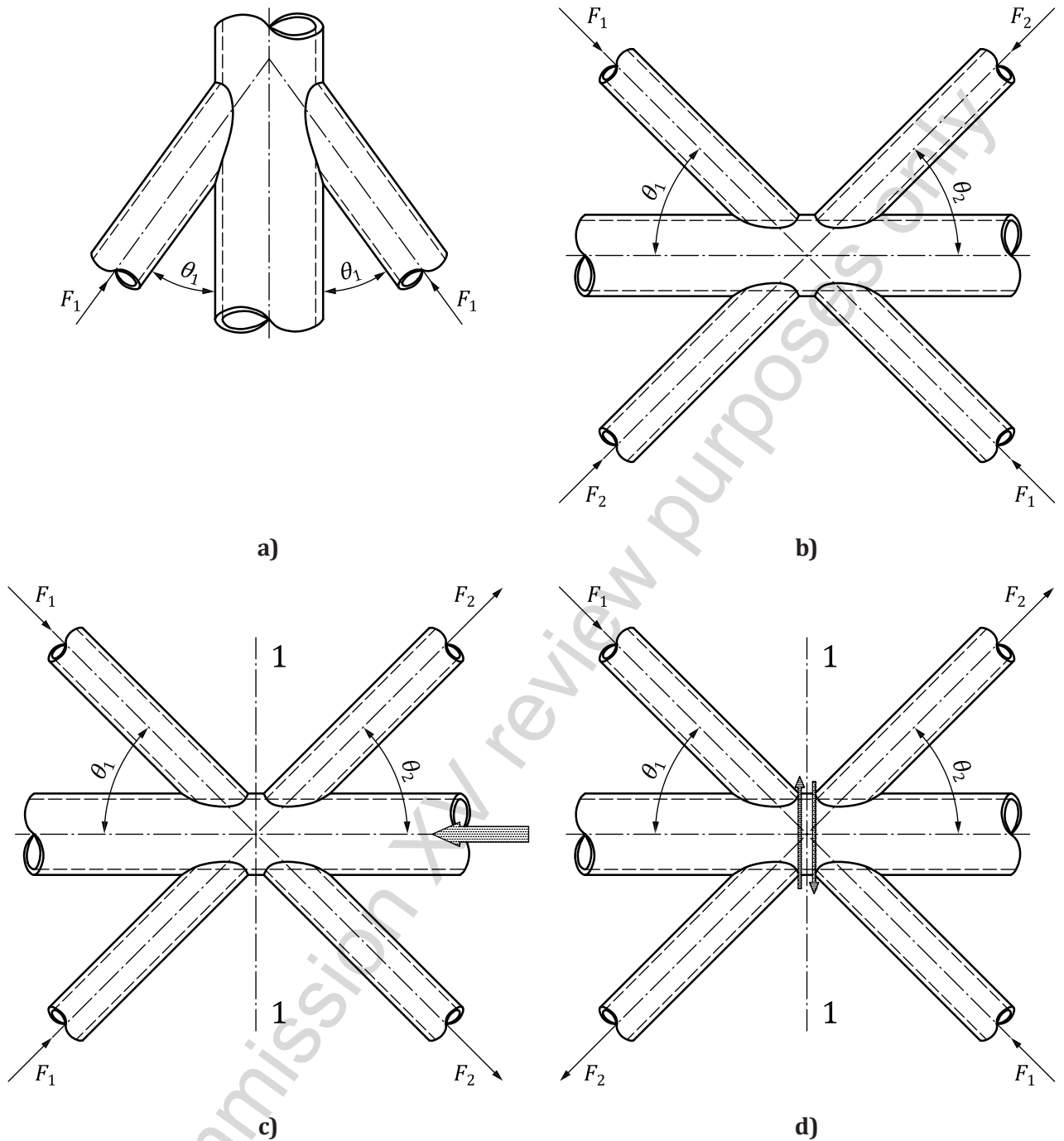

Figure 8 — Special types of uniplanar joints

The following criteria apply:

in the joint in Figure 8 a), $F_1 \leq F_1^*$, in which F_1^* is the design resistance of an X-joint given in Table 2 or Table 6;

in the joint in Figure 8 b), $F_1 \sin \theta_1 + F_2 \sin \theta_2 \leq F_i^* \sin \theta_i$, in which F_i^* is the design resistance of an X-joint given in Table 2 or Table 6, where $F_i^* \sin \theta_i$ is the larger of $F_1^* \sin \theta_1$ and $F_2^* \sin \theta_2$;

in the joint in Figure 8 c), $F_1 \leq F_1^*$ and $F_2 \leq F_2^*$, in which F_1^* and F_2^* are the design resistances of a K-joint, given in Table 2 or Table 6 — the force in the chord is the total chord force;

in the joint in Figure 8 d), $F_1 \leq F_1^*$ and $F_2 \leq F_2^*$, in which F_1^* and F_2^* are the design resistances of a K-joint, given in Table 2 or Table 6.

Further, the following chord shear criteria apply at section 1-1 in Figure 8 d).

For CHS gap joints:

$$\left(\frac{F_{\text{gap},0}}{F_{\text{pl},0}} \right)^2 + \left(\frac{F_{\text{s,gap},0}}{F_{\text{s,pl},0}} \right)^2 \leq 1,0$$

in which $F_{\text{gap},0}$ is the design value of the axial force in the chord, $F_{\text{s,gap},0}$ is the design value of the shear force in the chord, both at the gap location. $F_{\text{pl},0}$ is the axial yield capacity of the chord, i.e. $F_{\text{pl},0} = A_0 \sigma_{y0}$,

and $F_{\text{s,pl},0}$ is the shear yield capacity of the chord, i.e. $F_{\text{s,pl},0} = 0,58 \sigma_{y0} \frac{2A_0}{\pi}$

For gap joints with an RHS chord or an I- or H-section chord:

$$F_{\text{s,gap},0} \leq F_{\text{s,pl},0} = 0,58 \sigma_{y0} A_s \text{ and } F_{\text{gap},0} \leq F_{\text{gap},0}^* = (A_0 - A_s) \sigma_{y0} + A_s \sigma_{y0} \sqrt{1 - \left(\frac{F_{\text{s,gap},0}}{F_{\text{s,pl},0}} \right)^2}$$

in which A_s is given in Table 6 for RHS chord joints, and Table 11 for I- or H-section chord joints.

13.5 Multiplanar joints

13.5.1 Multiplanar joints with CHS chord

For multiplanar joints with CHS chord, as described in Clause 16, the following design criteria apply.

In each relevant plane of a multiplanar joint, the design criteria given in 13.2.1 and 13.2.2 shall be satisfied using the design resistance with the multiplanar factors given in Table 5.

13.5.2 Multiplanar joints with RHS chord

For multiplanar joints with RHS chord, as described in Clause 20, the following design criteria apply.

In each relevant plane of a multiplanar joint, the design criteria given in 13.2.1 and 13.2.3 shall be satisfied using the design resistance with the multiplanar factors given in Table 10.

14 Design resistance of uniplanar CHS braces to CHS chord joints

14.1 Design axial resistance

The design axial resistance of uniplanar CHS to CHS joints shall be determined using Table 2.

Table 2 — Design axial resistance of uniplanar CHS braces to CHS chord joints

Limit state		Axially loaded joints with CHS braces and chord		
Chord plastification		$F_i^* = Q_u Q_f \frac{\sigma_{y0} t_0^2}{\sin \theta_i}$		
Chord punching shear (for $d_i \leq d_0 - 2t_0$)		$F_i^* = 0,58 \sigma_{y0} \pi d_i t_0 \frac{1 + \sin \theta_i}{2 \sin^2 \theta_i}$		
Function Q_u				
T- and Y-joints See Figure 1 a) and b)		$Q_u = 2,6 (1 + 6,8 \beta^2) \gamma^{0,2}$		
X-joints ^a See Figure 1 c)		$Q_u = 2,6 \left(\frac{1 + \beta}{1 - 0,7 \beta} \right) \gamma^{0,15}$		
Gap K-joints See Figure 1 h)		$Q_u = 1,65 (1 + 8 \beta^{1,6}) \gamma^{0,3} \left[1 + \frac{1}{1,2 + (g/t_0)^{0,8}} \right]$		
Function Q_f				
	$Q_f = (1 - n)^{C_1}$	$n = \frac{F_0}{F_{pl,0}} + \frac{M_0}{M_{pl,0}}$ in connecting face		
	Chord compression stress ($n < 0$)	Chord tension stress ($n \geq 0$)		
T, Y- and X-joints	$C_1 = 0,45 - 0,25 \beta$	$C_1 = 0,20$		
Gap K-joints	$C_1 = 0,25$			
Range of validity				
General	$0,2 \leq d_i/d_0 \leq 1,0$	$e/d_0 \leq 0,25$	$g \geq t_1 + t_2$	
	$\theta_i \geq 30^\circ$	$\sigma_{yi} \leq \sigma_{y0}$ and $\sigma_y \leq 0,8 \sigma_u$		
CHS chord	Compression	class 1 or 2 ^b and $d_0/t_0 \leq 50$ (for X-joints: $d_0/t_0 \leq 40$)		
	Tension	$d_0/t_0 \leq 50$ (for X-joints: $d_0/t_0 \leq 40$)		
CHS braces	Compression	class 1 or 2 and $d_i/t_i \leq 50$		
	Tension	$d_i/t_i \leq 50$		
^a For X-joints with $\cos \theta_1 > \beta$, the chord should also be checked for shear failure. ^b Examples of cross-section classification can be found in Eurocode 3 (see EN 1993-1-1:2005,[4] 5.5).				

14.2 Design moment resistance

The design moment resistance of uniplanar CHS to CHS joints shall be determined using Table 3.

Table 3 — Design moment resistance of uniplanar CHS braces to CHS chord joints

Limit state	Joints with CHS braces and chord	
Chord plastification	$M_1^* = Q_u Q_f \frac{\sigma_{y0} t_0^2}{\sin \theta_1} d_1$	
Chord punching shear (for $d_1 \leq d_0 - 2t_0$)	$M_1^* = 0,58 \sigma_{y0} d_1^2 t_0 \frac{k_b}{\sin \theta_1}$	
	Brace in-plane bending $k_b = \frac{1 + 3 \sin \theta_1}{4 \sin \theta_1}$	Brace out-of-plane bending $k_b = \frac{3 + \sin \theta_1}{4 \sin \theta_1}$
Function Q_u		
	Brace in-plane bending See Figure 1 f)	Brace out-of-plane bending See Figure 1 g)
T-, Y-, X- and gap K-joints	$Q_u = 4,3 \beta \gamma^{0,5}$	$Q_u = 1,3 \left(\frac{1 + \beta}{1 - 0,7 \beta} \right) \gamma^{0,15}$
Function Q_f	Same as in Table 2	
Range of validity	Same as in Table 2	

15 Design resistance of uniplanar gusset plates, I- or H-section braces or RHS braces to CHS chord joints

The design resistance of uniplanar gusset plate to CHS joints shall be determined using Table 4.

Table 4 — Design resistance of uniplanar gusset plates, I- or H-section braces or RHS braces to CHS chord joints

Limit state	Brace axial load	Brace bending moment		
Chord plastification	$F_1^* = Q_u Q_f \frac{\sigma_{y0} t_0^2}{\sin \theta_1}$	$M_1^* = Q_{ub} Q_f \frac{\sigma_{y0} t_0^2}{\sin \theta_1} h_1$		
Chord punching shear (for $b_1 \leq d_0 - 2t_0$)	I-section with $\eta \leq 2$ (axial loading and out-of-plane bending) and RHS	$\frac{F_1}{A_1} + \frac{M_{ip,1}}{W_{el,ip,1}} + \frac{M_{op,1}}{W_{el,op,1}} \leq 0,58 \sigma_{y0} \frac{t_0}{t_1}$		
	All other cases	$\frac{F_1}{A_1} + \frac{M_{ip,1}}{W_{el,ip,1}} + \frac{M_{op,1}}{W_{el,op,1}} \leq 1,16 \sigma_{y0} \frac{t_0}{t_1}$		
	Function Q_u		Function Q_{ub} in terms of Q_u	
CHS chord with	Brace axial load	Brace in-plane bending	Brace out-of-plane bending	
Transverse plate ^{ab} See Figure 2 a) See Figure 2 b)	T	$Q_u = 2,2 (1 + 6,8 \beta^2) \gamma^{0,2}$	$Q_{ub} = 0$	$Q_{ub} = 0,5 Q_u \frac{b_1}{h_1}$
	X	$Q_u = 2,2 \left(\frac{1 + \beta}{1 - 0,7 \beta} \right) \gamma^{0,15}$	$Q_{ub} = 0$	$Q_{ub} = 0,5 Q_u \frac{b_1}{h_1}$

Table 4 (continued)

Limit state		Brace axial load	Brace bending moment	
Longitudinal plate^b See Figure 2 c) See Figure 2 d)	T	$Q_u = 5(1 + 0,4\eta)$	$Q_{ub} = 0,8Q_u$	$Q_{ub} = 0$
	X			
I-section or RHS^a See Figure 3 a) or c) See Figure 3 b) or d)	T	$Q_u = 2,2(1 + 6,8\beta^2)(1 + 0,4\eta)\gamma^{0,2}$	$Q_{ub} = \frac{Q_u}{(1 + 0,4\eta)}$	$Q_{ub} = 0,5Q_u \frac{b_1}{h_1}$
	X	$Q_u = 2,2\left(\frac{1 + \beta}{1 - 0,7\beta}\right)(1 + 0,4\eta)\gamma^{0,15}$	$Q_{ub} = \frac{Q_u}{(1 + 0,4\eta)}$	$Q_{ub} = 0,5Q_u \frac{b_1}{h_1}$
Function Q_f				
		$Q_f = (1 - n)^{C_1}$	$n = \frac{F_0}{F_{pl,0}} + \frac{M_0}{M_{pl,0}}$ in connecting face	
		Brace axial load/Brace in-plane bending and out-of-plane bending		
		Chord compression stress ($n < 0$)	Chord tension stress ($n \geq 0$)	
All joints		$C_1 = 0,25$	$C_1 = 0,20$	
Range of validity				
General		Same as in Table 2 with additional limits given below		
RHS braces	Compression	class 1 or 2 and $b_1/t_1 \leq 40$ and $h_1/t_1 \leq 40$		
	Tension	$b_1/t_1 \leq 40$ and $h_1/t_1 \leq 40$		
I-section braces	Compression	class 1 or 2		
	Tension	none		
Transverse plate		$b_1/d_0 \geq 0,4$		
Longitudinal plate		$1 \leq h_1/d_0 \leq 4$		
^a	The chord should also be checked for shear failure for: X-joints with transverse plates and angles $\theta_1 < 90^\circ$; X-joints with RHS or I-section brace members and $\cos \theta_1 > h_1/d_0$.			
^b	For transverse and longitudinal plates, θ_1 is the angle of the force acting on the plate.			

16 Design resistance of multiplanar joints with CHS chord

The design resistance for each relevant plane of a multiplanar joint shall be determined by applying the appropriate multiplanar factor μ given in Table 5 to the resistance of the corresponding uniplanar joint calculated according to Table 2, taking account of the actual chord force in the multiplanar joint.

Table 5 — Multiplanar factors for multiplanar CHS joints

Type of joint	Multiplanar factor μ
TT-joints See Figure 1 j) Member 1 may be either in tension or compression	$\mu = 1,0$
XX-joints See Figure 1 l) Members 1 and 2 can be either in compression or tension	$\mu = 1 + 0,35 \frac{F_2}{F_1}$ NOTE Take account of the sign of F_1 and F_2 with $ F_1 \geq F_2 $; F_2/F_1 is negative if the members in one plane are in tension and in the other plane in compression
KK-joints See Figure 1 n) Members 1 are always in compression and members 2 are always in tension	$\mu = 1,0$ Further, in a gap joint, the cross-section in the gap has to be checked for shear failure $\left(\frac{F_{gap,0}}{F_{pl,0}}\right)^2 + \left(\frac{F_{s,gap,0}}{F_{s,pl,0}}\right)^2 \leq 1,0$ with $F_{pl,0} = A_0\sigma_{y0}$ and $F_{s,pl,0} = 0,58\sigma_{y0} \frac{2A_0}{\pi}$
Range of validity	Same as in Table 2 $60^\circ \leq \phi \leq 90^\circ$

17 Design resistance of uniplanar RHS braces or CHS braces to RHS chord joints

17.1 Design axial resistance

The design axial resistance of uniplanar RHS or CHS braces to RHS chord joints shall be determined using Table 6.

Table 6 — Design resistance of uniplanar RHS braces or CHS braces to RHS chord joints

Limit state	Axially loaded uniplanar joints with RHS chord
Chord plastification (general check for gap K-joints; for T-, Y- and X-joints, if $\beta \leq 0,85$)	$F_i^* = Q_u Q_f \frac{\sigma_{y0} t_0^2}{\sin \theta_i}$
Local yielding of brace	$F_i^* = \sigma_{yi} t_i \ell_{b,eff.}$
Chord punching shear (for $b_1 \leq b_0 - 2t_0$)	$F_i^* = \frac{0,58\sigma_{y0} t_0}{\sin \theta_i} \ell_{p,eff.}$
Chord shear (general check for gap K-joints; for X-joints, if $\cos \theta_1 > h_1/h_0$)	$F_i^* = \frac{0,58\sigma_{y0} A_s}{\sin \theta_i}$
	$F_{gap,0}^* = (A_0 - A_s)\sigma_{y0} + A_s\sigma_{y0} \sqrt{1 - \left(\frac{F_{s,gap,0}}{F_{s,pl,0}}\right)^2}$

Table 6 (continued)

Limit state	Axially loaded uniplanar joints with RHS chord	
Chord side wall failure (only for T-, Y- and X-joints with $\beta = 1,0$)	$F_i^* = \frac{\sigma_k t_0}{\sin \theta_i} b_w Q_f$	
Function Q_u		
T-, Y- and X-joints See Figure 1 a), Figure 1 b) and c)	$Q_u = \frac{2\eta}{(1-\beta)\sin\theta_1} + \frac{4}{\sqrt{1-\beta}}$	
Gap K-joints See Figure 1 h)	$Q_u = 14\beta\gamma^{0,3}$	
Function Q_f		
	$Q_f = (1- n)^{C_1}$	$n = \frac{F_0}{F_{pl,0}} + \frac{M_0}{M_{pl,0}}$ in connecting face
	Chord compression stress ($n < 0$)	Chord tension stress ($n \geq 0$)
T-, Y- and X-joints	$C_1 = 0,6 - 0,5\beta$	$C_1 = 0,10$
Gap K-joints	$C_1 = 0,5 - 0,5\beta$ but $\geq 0,10$	
$\ell_{b,eff.}$ and $\ell_{p,eff.}$		$\ell_{p,eff.}$
T-, Y- and X-joints	$\ell_{b,eff.} = (2h_i + 2b_e - 4t_1)$	$\ell_{p,eff.} = \left(\frac{2h_1}{\sin\theta_1} + 2b_{e,p} \right)$
Gap K-joints	$\ell_{b,eff.} = (2h_i + b_i + b_e - 4t_i)$	$\ell_{p,eff.} = \left(\frac{2h_i}{\sin\theta_i} + b_i + b_{e,p} \right)$
	$b_e = \left(\frac{10}{b_0/t_0} \right) \left(\frac{\sigma_{y0}t_0}{\sigma_{yi}t_i} \right) b_i$ but $\leq b_i$	$b_{e,p} = \left(\frac{10}{b_0/t_0} \right) b_i$ but $\leq b_i$
A_s and $F_{s,pl,0}$	$F_{s,pl,0} = 0,58\sigma_{y0}A_s$	
T-, Y- and X-joints	$A_s = 2h_0t_0$	
Gap K-joints	$A_s = 2h_0t_0 + \alpha b_0t_0$	
	RHS braces	CHS braces
	$\alpha = \sqrt{\frac{1}{1+(4g^2)/(3t_0^2)}}$	$\alpha = 0$
b_w	$\beta = 1,0$	$0,85 < \beta < 1,0$
T-, Y- and X-joints	$b_w = \left(\frac{2h_1}{\sin\theta_1} + 10t_0 \right)$	Use linear interpolation between the resistance for chord plastification at $\beta = 0,85$ and the resistance for chord side wall failure at $\beta = 1,0$
Gap K-joints	N/A	
σ_k	Brace tension	Brace compression

Table 6 (continued)

Limit state		Axially loaded uniplanar joints with RHS chord	
$\sigma_k = \sigma_{y0}$		T- and Y-joints	X-joints
		$\sigma_k = \chi\sigma_{y0}$	$\sigma_k = 0,8\chi\sigma_{y0} \sin\theta_1$
		where χ is the reduction factor for column buckling according to e.g. Eurocode 3, using the relevant buckling curve and a slenderness $\lambda = 3,46 \left(\frac{h_0}{t_0} - 2 \right) \sqrt{\frac{1}{\sin\theta_1}}$	
T-, Y-, X-, and gap K-joints with CHS brace		For CHS braces, multiply the above resistances by $\pi/4$ (except for the chord shear criterion) and replace b_i and h_i by d_i ($i = 1, 2$)	
Range of validity			
		T-, Y- or X-joints	Gap K-joints
Brace-to-chord ratio	RHS braces	$b_i/b_0 \geq 0,1 + 0,01b_0/t_0$ but $\geq 0,25$	
	CHS braces	$d_i/b_0 \geq 0,1 + 0,01b_0/t_0$ and $0,25 \leq d_i/b_0 \leq 0,80$	
RHS chord	Compression	class 1 or 2 and $b_0/t_0 \leq 40$ and $h_0/t_0 \leq 40$	
	Tension	$b_0/t_0 \leq 40$ and $h_0/t_0 \leq 40$	
RHS braces	Compression	class 1 or 2 and $b_i/t_i \leq 40$ and $h_i/t_i \leq 40$	
	Tension	$b_i/t_i \leq 40$ and $h_i/t_i \leq 40$	
CHS braces	Compression	class 1 or 2 and $d_i/t_i \leq 50$	
	Tension	$d_i/t_i \leq 50$	
Gap		N/A	$0,5(1-\beta) \leq g/b_0 \leq 1,5(1-\beta)^a$ and $g \geq t_1 + t_2$
Eccentricity		N/A	$e \leq 0,25h_0$
Aspect ratio		$0,5 \leq h_i/b_i \leq 2,0$	
Brace angle		$\theta_i \geq 30^\circ$	
Yield stress		$\sigma_{yi} \leq \sigma_{y0}$ and $\sigma_y \leq 0,8\sigma_u$	
^a For $g/b_0 > 1,5(1-\beta)$, check the joint also as two separate T- or Y-joints.			

17.2 Design moment resistance

The design moment resistance of uniplanar RHS braces to RHS chord joints shall be determined using Table 7.

Table 7 — Design moment resistance of uniplanar RHS braces to RHS chord joints

Limit state	T- and X-joints ($\theta_1 = 90^\circ$) ^a			
	Brace in-plane bending		Brace out-of-plane bending ^b	
	See Figure 1 f)		See Figure 1 g)	
Chord plastification (for $\beta \leq 0,85$)	$M_{ip,1}^* = Q_u Q_f \sigma_{y0} t_0^2 h_1$		$M_{op,1}^* = Q_u Q_f \sigma_{y0} t_0^2 b_1$	
Local yielding of brace (for $0,85 < \beta \leq 1,0$)	$M_{ip,1}^* = \sigma_{y1} [W_{pl,1} - (1 - \frac{b_e}{b_1}) b_1 (h_1 - t_1) t_1]$		$M_{op,1}^* = \sigma_{y1} [W_{pl,1} - 0,5 t_1 (b_1 - b_e)^2]$	
Chord side wall failure (for $\beta = 1,0$) ^c	$M_{ip,1}^* = 0,5 \sigma_k t_0 (h_1 + 5t_0)^2 Q_f$		$M_{op,1}^* = \sigma_k t_0 (b_0 - t_0) (h_1 + 5t_0) Q_f$	
Function Q_u	Brace in-plane bending		Brace out-of-plane bending	
	$Q_u = \left(\frac{1}{2\eta} + \frac{2}{\sqrt{1-\beta}} + \frac{\eta}{1-\beta} \right)$		$Q_u = \left[\frac{h_1(1+\beta)}{2b_1(1-\beta)} + \sqrt{\frac{2(1+\beta)}{\beta(1-\beta)}} \right]$	
Function Q_f	Same as in Table 6			
b_e	$b_e = \left(\frac{10}{b_0/t_0} \right) \left(\frac{\sigma_{y0} t_0}{\sigma_{y1} t_1} \right) b_1$ but $\leq b_1$			
σ_k	Brace in-plane bending		Brace out-of-plane bending	
	T- and Y-joints	X-joints	T- and Y-joints	X-joints
	$\sigma_k = \sigma_{y0}$	$\sigma_k = 0,8\chi\sigma_{y0}$	$\sigma_k = \chi\sigma_{y0}$	$\sigma_k = 0,8\chi\sigma_{y0}$
	where χ is the reduction factor for column buckling according to e.g. Eurocode 3 (see EN 1993-1-1 ^[4]) of using the relevant buckling curve and a slenderness			
	$\lambda = 3,46 \left(\frac{h_0}{t_0} - 2 \right)$			
Range of validity	Same as in Table 6, but $\theta_1 \approx 90^\circ$ (see footnote a)			
^a The equations are conservative for $\theta_1 < 90^\circ$. ^b Chord distortion to be prevented for brace out-of-plane bending. ^c For $0,85 < \beta < 1,0$, use linear interpolation between the resistance for chord plastification at $\beta = 0,85$ and the resistance for chord side wall failure at $\beta = 1,0$.				

18 Design resistance of uniplanar SHS or CHS braces to SHS chord joints

18.1 Design axial resistance

The design axial resistance of uniplanar SHS or CHS to SHS chord joints shall be determined using Table 8. These equations can be viewed as special cases of those presented in Table 6.

Table 8 — Design resistance of uniplanar SHS or CHS braces to SHS chord joints

Limit state	Axially loaded uniplanar joints with SHS chord		
Chord plastification	$F_i^* = Q_u Q_f \frac{\sigma_{y0} t_0^2}{\sin \theta_i}$		
Function Q_u			
T-, Y- and X-joints See Figure 1 a), b) and c)	$Q_u = \frac{2\eta}{(1-\beta)\sin\theta_1} + \frac{4}{\sqrt{1-\beta}}$		
Gap K-joints See Figure 1 h)	$Q_u = 14\beta\gamma^{0,3}$		
Function Q_f	Same as in Table 6		
T-, Y-, X-, and gap K-joints with CHS brace	For CHS braces, multiply the above resistances by $\pi/4$ and replace b_i and h_i by d_i ($i = 1, 2$)		
Range of validity			
General	Same as in Table 6 with additional limits given below		
SHS braces	T-, Y- and X-joints	$b_1/b_0 \leq 0,85$	
	Gap K-joints	$0,6 \leq (b_1 + b_2)/(2b_i) \leq 1,3$	$b_0/t_0 \geq 15$
CHS braces	Gap K-joints	$0,6 \leq (d_1 + d_2)/(2d_i) \leq 1,3$	$b_0/t_0 \geq 15$

18.2 Design moment resistance

The design moment resistance of uniplanar SHS brace to SHS chord joints shall be determined using Table 7 with $h_i = b_i$ and $h_0 = b_0$.

19 Design resistance of uniplanar gusset plate to RHS joints

The design axial resistance of uniplanar gusset plate to RHS joints shall be determined using Table 9.

Table 9 — Design axial resistance of uniplanar gusset plate to RHS joints

Type of joint	Limit state
T- and X-joints — transverse plate See Figure 2 e) and f)	Chord plastification (for $0,4 \leq \beta \leq 0,85$) $F_1^* = \sigma_{y0} t_0^2 \frac{2 + 2,8\beta}{\sqrt{1 - 0,9\beta}} Q_f$
	Local yielding of plate (for all β) $F_1^* = \sigma_{y1} t_1 b_e$
	Chord punching shear (for $0,85b_0 \leq b_1 \leq b_0 - 2t_0$) $F_1^* = 0,58\sigma_{y0} t_0 (2t_1 + 2b_{e,p})$
	Chord side wall failure (for $\beta \approx 1,0^a$) $F_1^* = \sigma_{y0} t_0 (2t_1 + 10t_0) Q_f$

Table 9 (continued)

Type of joint		Limit state	
T- and X-joints — longitudinal plate See Figure 2 g) and h)		Chord plastification $F_1^* = 2\sigma_{y0}t_0^2 \left(\eta + 2\sqrt{1 - \frac{t_1}{b_0}} \right) Q_f$	
T-joints — longitudinal through plate See Figure 2 i)		Chord plastification $F_1^* = 4\sigma_{y0}t_0^2 \left(\eta + 2\sqrt{1 - \frac{t_1}{b_0}} \right) Q_f$	
Function Q_f			
		$Q_f = (1 - n)^{C_1}$	$n = \frac{F_0}{F_{pl,0}} + \frac{M_0}{M_{pl,0}}$ in connecting face
		Chord compression stress ($n < 0$)	Chord tension stress ($n \geq 0$)
Transverse plate		$C_1 = 0,03\gamma$ but $\geq 0,10$	$C_1 = 0,10$
Longitudinal plate		$C_1 = 0,20$	
Factors			
b_e and $b_{e,p}$		$b_e = \left(\frac{10}{b_0/t_0} \right) \left(\frac{\sigma_{y0}t_0}{\sigma_{y1}t_1} \right) b_1$ but $\leq b_1$	$b_{e,p} = \left(\frac{10}{b_0/t_0} \right) b_1$ but $\leq b_1$
Range of validity			
RHS chord	Compression	class 1 or 2 and $b_0/t_0 \leq 40$ and $h_0/t_0 \leq 40$	
	Tension	$b_0/t_0 \leq 40$ and $h_0/t_0 \leq 40$	
	Aspect ratio	$0,5 \leq h_0/b_0 \leq 2,0$	
Transverse plate		$b_1/b_0 \geq 0,4$	
Longitudinal plate		$1 \leq h_1/b_0 \leq 4$	
Plate angle		$\theta_1 \approx 90^\circ$	
Yield stress		$\sigma_{y1} \leq \sigma_{y0}$ and $\sigma_y \leq 0,8\sigma_u$	
^a For $0,85 < \beta < 1,0$, use linear interpolation between the resistance for chord plastification at $\beta = 0,85$ and the resistance for chord side wall failure at $\beta = 1,0$.			

20 Design resistance of multiplanar joints with RHS chord

The design resistance for each relevant plane of a multiplanar joint shall be determined by applying the appropriate multiplanar factor μ given in Table 10 to the resistance of the corresponding uniplanar joint calculated according to Table 6, taking account of the actual chord force in the multiplanar joint.

Table 10 — Multiplanar factors for multiplanar RHS joints

Type of joint	Multiplanar factor μ
TT-joints See Figure 1 k) Member 1 may be either in tension or compression.	$\mu = 1,0$
XX-joints See Figure 1 m) Members 1 and 2 can be either in compression or tension.	$\mu = 1 + 0,35 \frac{F_2}{F_1} \leq 1,0 \text{ for } \beta \leq 0,85$ NOTE Take account of the sign of F_1 and F_2 with $ F_1 \geq F_2 $; F_2/F_1 is negative if the members in one plane are in tension and in the other plane in compression.
KK-joints See Figure 1 o) Members 1 are always in compression and members 2 are always in tension	$\mu = 1,0$ Further, in a gap joint, the cross-section in the gap has to be checked for shear failure. $\left(\frac{F_{\text{gap},0}}{F_{\text{pl},0}} \right)^2 + \left(\frac{0,71 F_{\text{s,gap},0}}{F_{\text{s,pl},0}} \right)^2 \leq 1,0$ with $F_{\text{pl},0} = A_0 \sigma_{y0}$ $F_{\text{s,pl},0} = 0,58 \sigma_{y0} (0,5 A_0) \text{ for an SHS chord}$
Range of validity	Same as in Table 6 $\phi \approx 90^\circ$

21 Design resistance of uniplanar CHS or RHS braces to I- or H-section chord joints

21.1 Design axial resistance

The design axial resistance of uniplanar CHS or RHS braces to I- or H-section chord joints shall be determined using Table 11.

Table 11 — Design axial resistance of uniplanar CHS or RHS braces to I- or H-section chord joints

Limit state	T-, Y-, X-, and gap K-joints See Figure 4 a) and b)		
Local yielding of brace	$F_i^* = 2\sigma_{yi} t_i b_e$		
Chord web failure	$F_i^* = \frac{\sigma_{y0} t_w b_w}{\sin\theta_i}$		
Chord shear	$F_i^* = \frac{0,58\sigma_{y0} A_s}{\sin\theta_i}$		
	$F_{\text{gap},0}^* = (A_0 - A_s)\sigma_{y0} + A_s\sigma_{y0} \sqrt{1 - \left(\frac{F_{\text{s,gap},0}}{F_{\text{s,pl},0}} \right)^2}$		
Factors			
	<table border="0" style="width: 100%;"> <tr> <td style="width: 50%; text-align: center;">RHS braces</td> <td style="width: 50%; text-align: center;">CHS braces</td> </tr> </table>	RHS braces	CHS braces
RHS braces	CHS braces		

Table 11 (continued)

b_e	$b_e = t_w + 2r + 7t_0 \frac{\sigma_{y0}}{\sigma_{yi}}$ but $b_e \leq b_i + h_i - 2t_i$	$b_e = t_w + 2r + 7t_0 \frac{\sigma_{y0}}{\sigma_{yi}}$ but $b_e \leq 0,5\pi (d_i - t_i)$		
b_w	$b_w = \frac{h_i}{\sin\theta_i} + 5(t_0 + r)$ but $b_w \leq \frac{2t_i}{\sin\theta_i} + 10 \leq (t_0 + r)$	$b_w = \frac{d_i}{\sin\theta_i} + 5(t_0 + r)$ but $b_w \leq \frac{2t_i}{\sin\theta_i} + 10(t_0 + r)$		
A_s	$A_s = A_0 - (2 - \alpha) b_0 t_0 + (t_w + 2r) t_0$			
	$\alpha = \sqrt{\frac{1}{1 + (4g^2)/(3t_0^2)}}$	$\alpha = 0$		
$F_{s,pl,0}$	$F_{s,pl,0} = 0,58\sigma_{y0}A_s$			
Range of validity				
		X joints	T- and Y-joints	Gap K-joints
I- or H-section chord	Compression	Flange	class 1 or 2	
		Web	class 1 and $d_w \leq 400$ mm	class 1 or 2 and $d_w \leq 400$ mm
	Tension	None		
CHS braces	Compression	class 1		
	Tension	$d_i/t_i \leq 50$		
RHS braces	Compression	class 1		
	Tension	$b_i/t_i \leq 40$ and $h_i/t_i \leq 40$		
	Aspect ratio	$0,5 \leq h_i/b_i \leq 2,0$		
Gap		N/A	$g \geq t_1 + t_2$	
Eccentricity		N/A	$e \leq 0,25h_0$	
Brace angle		$\theta_i \geq 30^\circ$		
Yield stress		$\sigma_{yi} \leq \sigma_{y0}$ and $\sigma_y \leq 0,8\sigma_u$		

21.2 Design moment resistance

The design moment resistance of uniplanar RHS braces (beams) to I- or H-section chord joints shall be determined using Table 12.

Table 12 — Design moment resistance of uniplanar RHS braces (beams) to I- or H-section chord joints

Limit state	T-joints See Figure 4 d)
Local yielding of brace	$M_{ip,1}^* = \sigma_{y1} t_1 b_e h_z$ where h_z is the distance between the centres of gravity of the effective parts of the RHS brace (beam)
Chord web failure	$M_{ip,1}^* = 0,5\sigma_{y0}t_w b_w(h_1 - t_1)$
Factors	
b_e	b_w
$b_e = t_w + 2r + 7t_0 \frac{\sigma_{y0}}{\sigma_{y1}}$ but $\leq b_1 + h_1 - 2t_1$	$b_w = h_1 + 5(t_0 + r)$ but $\leq 2t_1 + 10(t_0 + r)$
Range of validity	Same as in Table 11, but $\theta_1 \approx 90^\circ$

22 Design resistance of uniplanar overlap joints with a CHS, RHS, I- or H-section chord

The design axial resistance of uniplanar overlap joints with a CHS, RHS, I- or H-section chord shall be determined using Table 13 and Table 14. Effective width factors (b_{ei} , b_{ej} , $b_{e,ov}$ and d_{ei} , d_{ej} , $d_{e,ov}$) used in Tables 13 and 14 are given in Table 15.

Table 13 — Design axial resistance of uniplanar overlap joints with a CHS, RHS, I- or H-section chord

Limit state	Axially loaded overlap joints	
Local yielding of overlapping brace	$F_i^* = \sigma_{yi}t_i \ell_{b,eff.}$	
Local chord member yielding	$\left(\frac{F_0}{F_{pl,0}}\right)^c + \frac{M_0}{M_{pl,0}} \leq 1,0$	$c = 1,7$ for CHS chord
		$c = 1,0$ for RHS or I-section chord
Brace shear ^a (for $O_{v,limit} < O_v \leq 100\%$)	$F_i \cos\theta_i + F_j \cos\theta_j \leq F_s^*$ (see Table 14)	
	$\ell_{b,eff.}$	
	CHS braces	RHS braces
	See Figure 4 c)	
$25\% \leq O_v < 50\%$	$\ell_{b,eff.} = \frac{\pi}{4}(2d_i + d_{ei} + d_{e,ov} - 4t_i)$	$\ell_{b,eff.} = \left(\frac{O_v}{50}\right)2h_i + b_{ei} + b_{e,ov} - 4t_i$
$50\% \leq O_v < 100\%$		$\ell_{b,eff.} = 2h_i + b_{ei} + b_{e,ov} - 4t_i$
$O_v = 100\%$	$\ell_{b,eff.} = \frac{\pi}{4}(2d_i + 2d_{e,ov} - 4t_i)$	$\ell_{b,eff.} = 2h_i + b_i + b_{e,ov} - 4t_i$
General note	The efficiency (i.e. design resistance divided by the yield load) of the overlapped brace j shall not exceed that of the overlapping brace i	
Range of validity		

Table 13 (continued)

Limit state		Axially loaded overlap joints				
General		d_i / d_0 and $d_j / d_0 \geq 0,20$ b_i / b_0 and $b_j / b_0 \geq 0,25$ d_i / b_0 and $d_j / b_0 \geq 0,25$	$d_i / d_j \geq 0,75$ $b_i / b_j \geq 0,75$	t_i and $t_j \leq t_0$ $t_i \leq t_j$	θ_i and $\theta_j \geq 30^\circ$	$O_v \geq 25\%$
					σ_{yi} and $\sigma_{yj} \leq \sigma_{y0}$ and $\sigma_y \leq 0,8\sigma_u$	
Chord	CHS	Compression		class 1 or 2 and $d_0/t_0 \leq 50$		
		Tension		$d_0/t_0 \leq 50$		
	RHS	Compression		class 1 or 2 and $b_0/t_0 \leq 40$ and $h_0/t_0 \leq 40$		
		Tension		$b_0/t_0 \leq 40$ and $h_0/t_0 \leq 40$		
		Aspect ratio		$0,5 \leq h_0/b_0 \leq 2,0$		
	I- or H-section	Compression	Flange	class 1 or 2		
			Web	class 1 or 2 and $d_w \leq 400$ mm		
Tension		None				
		CHS or RHS chord		I- or H-section chord		
Braces	CHS	Compression		class 1 or 2 and $d_1/t_1 \leq 50$	class 1	
		Tension		$d_2/t_2 \leq 50$		
	RHS	Compression		class 1 or 2 and $b_1/t_1 \leq 40$ and $h_1/t_1 \leq 40$	class 1	
		Tension		$b_2/t_2 \leq 40$ and $h_2/t_2 \leq 40$		
		Aspect ratio		$0,5 \leq h_i/b_i \leq 2,0$ and $0,5 \leq h_j/b_j \leq 2,0$	$h_i/b_i = 1,0$ and $h_j/b_j = 1,0$	
^a $O_{v,limit} = 60\%$ if the hidden seam of the overlapped brace is not welded; $O_{v,limit} = 80\%$ if the hidden seam of the overlapped brace is welded.						

Table 14 — Design brace shear resistance of uniplanar overlap joints with a CHS, RHS or I-section chord

F_s^* for brace shear criterion (only to be checked for $O_{v,limit} < O_v \leq 100\%$) ^a		
CHS braces	$O_{v,limit} < O_v < 100\%$	$F_s^* = \frac{\pi}{4} \left\{ 0,58\sigma_{ui} \frac{\left[\left(\frac{100 - O_v}{100} \right) 2d_i + d_{ei} \right] t_i}{\sin\theta_i} + 0,58\sigma_{uj} \frac{(2d_j + c_s d_{ej}) t_j}{\sin\theta_j} \right\}$
	$O_v = 100\%$	$F_s^* = 0,58\sigma_{uj} \frac{\pi (3d_j + d_{ej}) t_j}{4 \sin\theta_j}$
RHS braces	$O_{v,limit} < O_v < 100\%$	$F_s^* = 0,58\sigma_{ui} \frac{\left[\left(\frac{100 - O_v}{100} \right) 2h_i + b_{ei} \right] t_i}{\sin\theta_i} + 0,58\sigma_{uj} \frac{(2h_j + c_s b_{ej}) t_j}{\sin\theta_j}$
	$O_v = 100\%$	$F_s^* = 0,58\sigma_{uj} \frac{(2h_j + b_j + b_{ej}) t_j}{\sin\theta_j}$

^a $O_{v,limit} = 60\%$ and $c_s = 1$ if hidden seam of the overlapped brace is not welded; $O_{v,limit} = 80\%$ and $c_s = 2$ if hidden seam of the overlapped brace is welded. In case of overlap joints with $h_i < b_i$ and/or $h_j < b_j$, the brace shear criterion shall always be checked.

Table 15 — Effective width factors (b_{ei} , b_{ej} , b_e , O_v and d_{ei} , d_{ej} , d_e , O_v) used in Tables 13 and 14

Factors for CHS braces to CHS chords	
CHS braces	
Overlapping CHS brace to CHS chord	
$d_{ei} = \left(\frac{12}{d_0/t_0} \right) \left(\frac{\sigma_{y0} t_0}{\sigma_{yi} t_i} \right) d_i \text{ but } \leq d_i$	
Overlapped CHS brace to CHS chord	
$d_{ej} = \left(\frac{12}{d_0/t_0} \right) \left(\frac{\sigma_{y0} t_0}{\sigma_{yj} t_j} \right) d_j \text{ but } \leq d_j$	
Overlapping CHS brace to overlapped CHS brace	
$d_{e,ov} = \left(\frac{12}{d_j/t_j} \right) \left(\frac{\sigma_{yj} t_j}{\sigma_{yi} t_i} \right) d_i \text{ but } \leq d_i$	
Factors for CHS or RHS braces to RHS chords	
CHS braces	RHS braces
Overlapping CHS brace to RHS chord	Overlapping RHS brace to RHS chord
$d_{ei} = \left(\frac{10}{b_0/t_0} \right) \left(\frac{\sigma_{y0} t_0}{\sigma_{yi} t_i} \right) d_i \text{ but } \leq d_i$	$b_{ei} = \left(\frac{10}{b_0/t_0} \right) \left(\frac{\sigma_{y0} t_0}{\sigma_{yi} t_i} \right) b_i \text{ but } \leq b_i$
Overlapped CHS brace to RHS chord	Overlapped RHS brace to RHS chord
$d_{ej} = \left(\frac{10}{b_0/t_0} \right) \left(\frac{\sigma_{y0} t_0}{\sigma_{yj} t_j} \right) d_j \text{ but } \leq d_j$	$b_{ej} = \left(\frac{10}{b_0/t_0} \right) \left(\frac{\sigma_{y0} t_0}{\sigma_{yj} t_j} \right) b_j \text{ but } \leq b_j$

Table 15 (continued)

Overlapping CHS brace to overlapped CHS brace	Overlapping RHS brace to overlapped RHS brace
$d_{e,ov} = \left(\frac{12}{d_j/t_j} \right) \left(\frac{\sigma_{yj}t_j}{\sigma_{yi}t_i} \right) d_i \text{ but } \leq d_i$	$b_{e,ov} = \left(\frac{10}{b_j/t_j} \right) \left(\frac{\sigma_{yj}t_j}{\sigma_{yi}t_i} \right) b_i \text{ but } \leq b_i$
Factors for CHS or RHS braces to I-section chords	
CHS braces	RHS braces
Overlapping CHS brace to I-section chord	Overlapping RHS brace to I-section chord
$d_{ei} = t_w + 2r + 7t_0 \frac{\sigma_{y0}}{\sigma_{yi}} \text{ but } \leq d_i$	$b_{ei} = t_w + 2r + 7t_0 \frac{\sigma_{y0}}{\sigma_{yi}} \text{ but } \leq b_i$
Overlapped CHS brace to I-section chord	Overlapped RHS brace to I-section chord
$d_{ej} = t_w + 2r + 7t_0 \frac{\sigma_{y0}}{\sigma_{yj}} \text{ but } \leq d_j$	$b_{ej} = t_w + 2r + 7t_0 \frac{\sigma_{y0}}{\sigma_{yj}} \text{ but } \leq b_j$
Overlapping CHS brace to overlapped CHS brace	Overlapping RHS brace to overlapped RHS brace
$d_{e,ov} = \left(\frac{12}{d_j/t_j} \right) \left(\frac{\sigma_{yj}t_j}{\sigma_{yi}t_i} \right) d_i \text{ but } \leq d_i$	$b_{e,ov} = \left(\frac{10}{b_j/t_j} \right) \left(\frac{\sigma_{yj}t_j}{\sigma_{yi}t_i} \right) b_i \text{ but } \leq b_i$

Annex A (informative)

Quality requirements for hollow sections

A.1 The grade and quality of steel chosen shall meet static strength and toughness requirements, taking into account weldability, restraint, thickness, environmental conditions, rate of loading, extent of cold forming, and the consequence of failure.

A.2 For SHS and RHS made by cold-forming which satisfy the requirements of Table A.1, the distance between the longitudinal seam and the tangent point to the external corner radius (r_o) should be at least twice the wall thickness ($2t$), as shown in Figure A.1. In those cases where Table A.1 is not satisfied, this distance should be increased to at least $5t$.

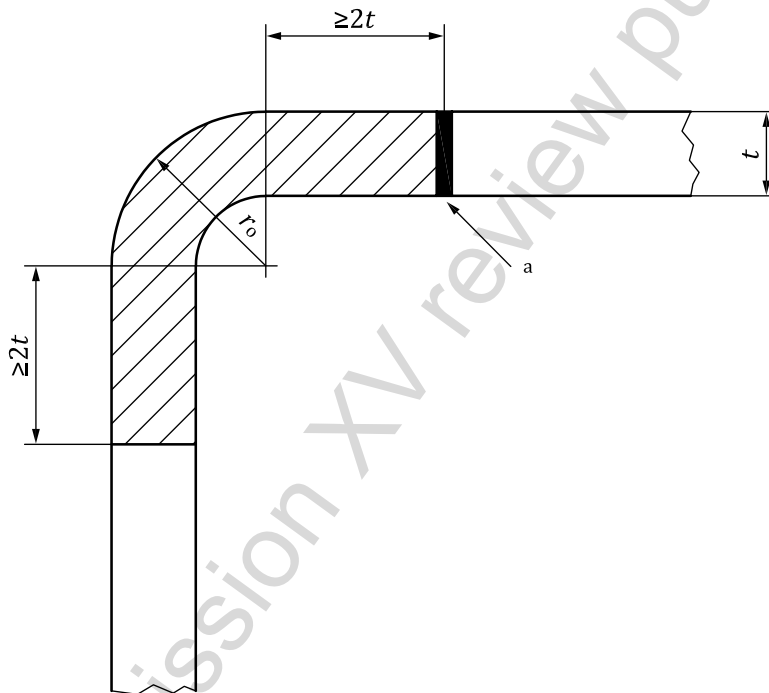

Key
a longitudinal seam

Figure A.1 — Distance between the longitudinal seam and the tangent point to the external corner radius

A.3 For SHS and RHS, welding is permitted in the zones of cold forming if the following conditions (see Table A.1) of external corner radius are satisfied. These restrictions do not apply if heat-treatment has been performed on cold-formed sections, to produce sections with compatible metallurgical properties to hot-finished sections.

Table A.1 — Conditions for welding in the cold-formed zone and adjacent material for SHS and RHS

RHS thickness mm	External corner radius for fully Al-killed steel (Al ≥ 0,02 % by mass) r_o	External corner radius for fully Al-killed steel <i>and</i> C ≤ 0,18 % by mass, P ≤ 0,02 % by mass and S ≤ 0,012 % by mass r_o
$2,5 \leq t \leq 6$	$\geq 2,0t$	$\geq 1,6t$
$6 < t \leq 10$	$\geq 2,5t$	$\geq 2,0t$
$10 < t \leq 12$	$\geq 3,0t$	$\geq 2,4t$ (up to $t = 12,5$)
$12 < t \leq 24$	$\geq 4,0t$	N/A

Annex B (informative)

Weld details

B.1 Except for K- and N-joints with partially overlapped brace members (as covered in Clause 22 by reference to the hidden seam), connection shall be established around the entire perimeter of a hollow-section brace member by means of a full penetration weld, a partial penetration weld, a fillet weld or a combination.

B.2 Recommendations advocated in this specification are for welds produced to normal structural welding standards, such as ISO 5817.^[23]

B.3 Welds shall satisfy one of the following conditions:

- a) welds are to be proportioned to be “fit for purpose” and to resist forces in the connected members, taking account of joint deformation or rotation capacity and considering weld effective lengths;
- b) welds are to be proportioned to achieve the capacity of the connected member walls — this will automatically prequalify the weld for any brace member loading.

B.4 For fillet welds:

- a) the local dihedral angle at the toe of the brace shall not exceed 120°;
- b) such welds are not generally recommended for wall thicknesses greater than 8 mm;
- c) when such welds are not feasible at the saddle regions of circular hollow-section joints, partial or full penetration welds shall be provided there, while fillet welds may be used at the crown toe and crown heel regions.

B.5 Weld start and stop positions for non-continuous welds should not be located at points of stress concentration. Some recommended locations for these weld start and stop positions are shown in Figure B.1.

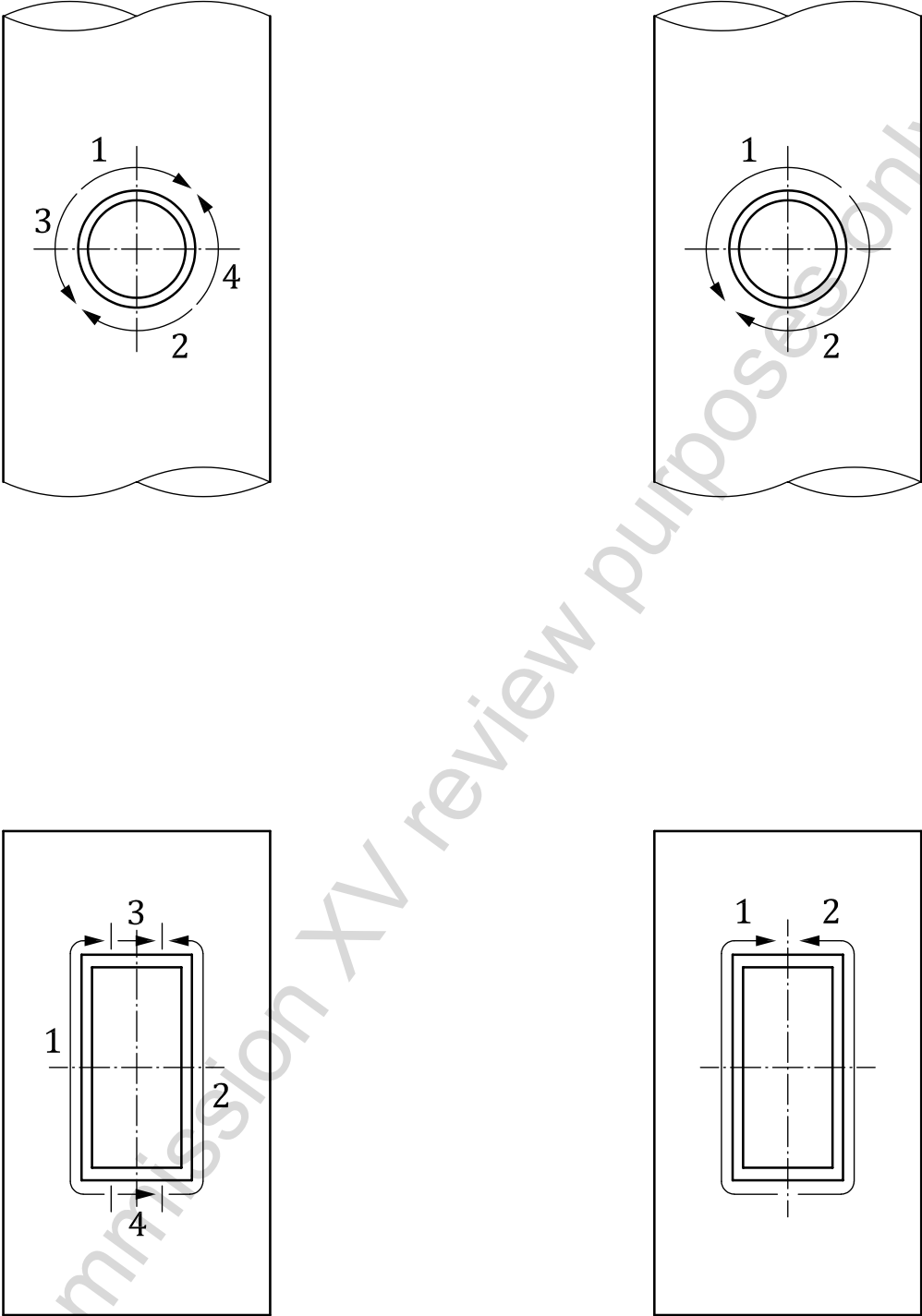

Figure B.1 — Recommended weld start and stop positions

Annex C (informative)

Partial safety factors on static strength

C.1 The partial safety factors that have been used in this International Standard for the calculation of the design resistances for the various joint types are given in Table C.1.

C.2 The partial safety factors (γ_M) given in Table C.1 are approximately equivalent to the reciprocal of the ϕ factors for LSD (LRFD), i.e. γ_M is approximately $1/\phi$.

IIW Commission XV review purposes only

Table C.1 — Partial safety factors on static strength

Type of joints	Failure criteria	Table	Partial safety factor γ_M
Uniplanar CHS to CHS joints	Chord face failure	2 and 3	1,1
	Punching shear		1,0 ^b
Uniplanar gusset plate to CHS joints	Chord face failure	4	1,1
	Punching shear		1,0 ^b
Uniplanar I-, H- or RHS to CHS joints	Chord face failure	4	1,1
	Punching shear		1,0 ^b
Uniplanar RHS or CHS to RHS chord joints	Chord face failure (T-, Y-, and X-joints)	6 and 7	1,0 ^b
	Chord face failure (gap K- and N-joints)		1,1
	Side wall failure (X-joint in compression)		1,25
	Side wall failure (T-, Y-, and X-joints in tension)		1,0 ^b
	Brace failure ^a		1,25
	Chord shear		1,0 ^b
	Punching shear ^a		1,25
Uniplanar SHS or CHS to SHS chord joints	Chord face failure (T-, Y-, and X-joints)	8	1,0 ^b
	Chord face failure (gap K-joints)		1,1
Uniplanar gusset plate to RHS joints	Brace failure ^a	9	1,25
	Chord side wall failure (X-joint in compression)		1,25
	Chord side wall failure (tension)		1,0 ^b
	Punching shear ^a		1,25
	Chord face failure		1,0 ^b
Uniplanar CHS or RHS to I- or H-section chord joints	Chord web failure	11 and 12	1,0 ^b
	Brace failure ^a		1,25
	Chord shear		1,0 ^b
All overlap joints	Brace failure ^a	13 and 14	1,25
	Chord member yield		1,0
	Brace shear		1,1

^a The γ_M factor is applied only to the effective width b_e , $b_{e,p}$ and $b_{e,ov}$.

^b The partial safety factor $\gamma_M = 1,0$ has been used in cases of lower bound theoretical yield criteria.

Bibliography

- [1] AISC. *Load and resistance factor design specification for steel hollow structural sections*. Chicago, IL: American Institute of Steel Construction, 2000. Available (viewed 2012-11-12) at: <http://gisceu.net/PDF/U187.pdf>
- [2] ANSI/AISC 360-10, *Specification for structural steel buildings*. Available (viewed 2012-11-12) at: <http://www.aisc.org/WorkArea/showcontent.aspx?id=26516>
- [3] AWS D1.1/D1.1M: 2010, *Structural welding code — Steel*
- [4] EN 1993-1-1, *Eurocode 3: Design of steel structures — Part 1-1: General rules and rules for buildings*
- [5] EN 1993-1-8, *Eurocode 3: Design of steel structures — Part 1-8: Design of joints*
- [6] EN 10210-2, *Hot finished structural hollow sections of non-alloy and fine grain steels — Part 2: Tolerances, dimensions and sectional properties*
- [7] EN 10219-2, *Cold formed welded structural hollow sections of non-alloy and fine grain steels — Part 2: Tolerances, dimensions and sectional properties*
- [8] DUTTA D., WARDENIER J., YEOMANS N., SAKAE K., BUCAK Ö., PACKER J.A. *Design guide for fabrication, assembly and erection of hollow section structures*. Cologne: Verlag TÜV Rheinland, 1998. (CIDECT Series: Construction with hollow steel sections, Vol. 7)
- [9] DUTTA D. *Structures with hollow sections*. Darmstadt: Ernst & Sohn, 2000
- [10] IIW XV-491-81, *Design recommendations for hollow section joints — Predominantly statically loaded*
- [11] IIW XV-701-89, *Design recommendations for hollow section joints — Predominantly statically loaded*
- [12] IIW XV-1402-12, *Static design procedure for welded hollow section joints — Recommendations*
- [13] KUROBANE Y., PACKER J.A., WARDENIER J., YEOMANS N. *Design guide for structural hollow section column connections*. Cologne: Verlag TÜV Rheinland, 2004. (CIDECT Series: Construction with hollow steel sections, Vol. 9)
- [14] MARSHALL P.W. *Design of welded tubular connections — Basis and use of AWS code provisions*. Amsterdam: Elsevier, 1992
- [15] PACKER J.A. HENDERSON J.E. *Hollow structural section connections and trusses — A design guide*. Toronto: Canadian Institute of Steel Construction, Second Edition, 1997
- [16] PACKER J.A., SHERMAN D.R., LECCE M. *Hollow structural section connections*. Chicago, IL: American Institute of Steel Construction, 2010. (*Steel Design Guide*, No. 24.)
- [17] PACKER J.A., WARDENIER J., ZHAO X.L., VAN DER VEGTE G.J., KUROBANE Y. *Design guide for rectangular hollow section (RHS) joints under predominantly static loading*. Geneva: CIDECT, 2nd Edition, 2009. (CIDECT Series: Construction with hollow steel sections, Vol. 3)
- [18] SEDLACEK G., VÖLLING B., PAK D., FELDMANN M. Local buckling behaviour of cold-formed RHS made from S1100. In: *Proceedings of 11th International Symposium on Tubular Structures*, Québec, Canada, 2006, pp. 147–152
- [19] WARDENIER J. *Hollow section joints*. Delft: Delft University Press, 1982
- [20] WARDENIER J., KUROBANE Y., PACKER J.A., VAN DER VEGTE G.J., ZHAO X.L. *Design guide for circular hollow section (CHS) joints under predominantly static loading*. Geneva: CIDECT, 2nd Edition, 2008. (CIDECT Series: Construction with hollow steel sections, Vol. 1)

- [21] WARDENIER J., PACKER J.A., ZHAO X.L., VAN DER VEGTE G.J. *Hollow sections in structural applications*. Geneva: CIDECT, Second Edition, 2010
- [22] ZHAO X.L., WARDENIER J., PACKER J.A., VAN DER VEGTE G.J. New IIW (2008) static design recommendations for hollow section joints. In: *Proceedings of 12th International Symposium on Tubular Structures*, Shanghai, China, 2008, pp. 261-270
- [23] ISO 5817, *Welding — Fusion-welded joints in steel, nickel, titanium and their alloys (beam welding excluded) — Quality levels for imperfections*

IIW Commission XV review purposes only